



K30

BLIND CONTROLLER AND MINI-PROGRAMMER



Engineering MANUAL

Code : MK30ENG00 - Vr. 0.0 (ENG)

1. OUTLINE DIMENSIONS (mm)

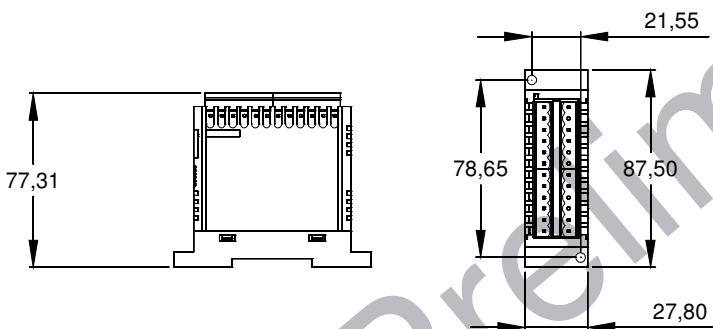

2. CONNECTION DIAGRAM

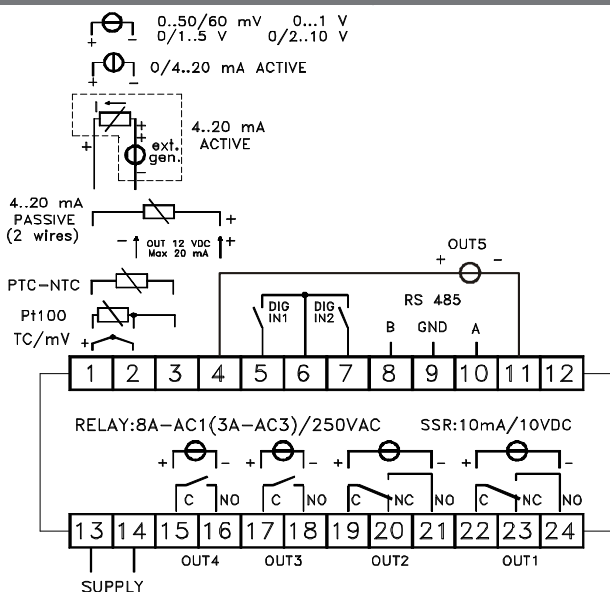

2.1 - MOUNTING REQUIREMENTS

This instrument is intended for permanent installation, for indoor use only, in an electrical panel which encloses the rear housing, exposed terminals and wiring on the back. Select a mounting location having the following characteristics:

- 1) it should be easily accessible
- 2) there is minimum vibrations and no impact
- 3) there are no corrosive gases
- 4) there are no water or other fluid (i.e. condensation)
- 5) the ambient temperature is in accordance with the operative temperature (from 0 to 50 °C)
- 6) the relative humidity is in accordance with the instrument specifications (20% to 85 %)

The instrument can be mounted on panel with a maximum thick of 15 mm.

When the maximum front protection (IP65) is desired, the optional gasket must be monted.

2.2 GENERAL NOTES ABOUT INPUT WIRING

- 1) Don't run input wires together with power cables.
- 2) External components (like zener barriers, etc.) connected between sensor and input terminals may cause errors in measurement due to excessive and/or not balanced line resistance or possible leakage currents.
- 3) When a shielded cable is used, it should be connected at one point only.
- 4) Pay attention to the line resistance; a high line resistance may cause measurement errors.

2.3 THERMOCOUPLE INPUT

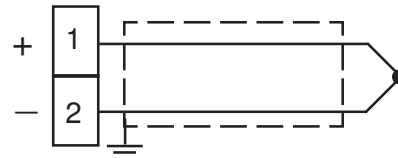

Fig. 3- Thermocouple input wiring

External resistance: 100 Ω max, maximum error 0,5 % of span.

Cold junction: automatic compensation from 0 to 50 °C.

Cold junction accuracy : 0.1 °C/°C after a warm-up of 20 minutes

Input impedance: > 1 MΩ

Calibration: according to EN 60584-1.

NOTE: for TC wiring use proper compensating cable preferable shielded.

2.4 INFRARED SENSOR INPUT

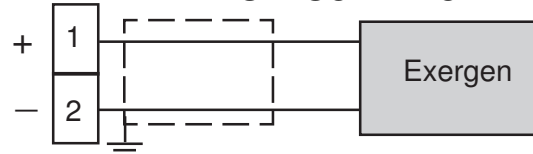

Fig. 4- Infrared input wiring

External resistance: don't care condition.

Cold junction: automatic compensation from 0 to 50 °C.

Cold junction accuracy : 0.1 °C/°C
 Input impedance: > 1 MΩ

2.5 RTD (Pt 100) INPUT

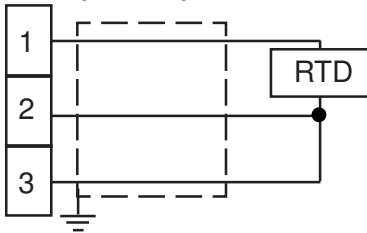

Fig. 5- RTD input wiring

Input circuit: current injection (135 μA).

Line resistance: automatic compensation up to 20 Ω/ wire with maximum error ± 0.1% of the input span.

Calibration: according to EN 60751/A2.

NOTE: The resistance of the 3 wires **must** be the same.

2.6 THERMISTORS INPUT

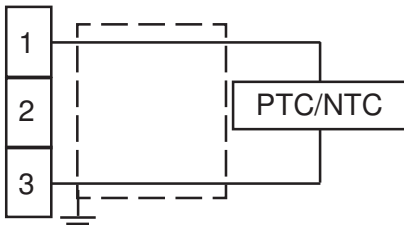

Fig. 6- PTC / NTC input wiring

Input circuit: current injection (25 μA).

Line resistance: not compensated.

2.7 V AND mV INPUT

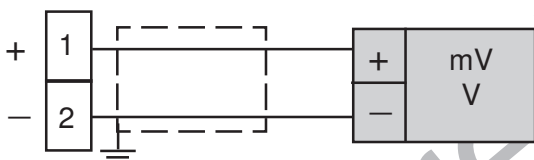

Fig. 7- V / mV input wiring

Input impedance: > 1 MΩ

Accuracy : ± 0.5 % of Span ± 1 dgt @ 25 °C.

2.8 - mA INPUT

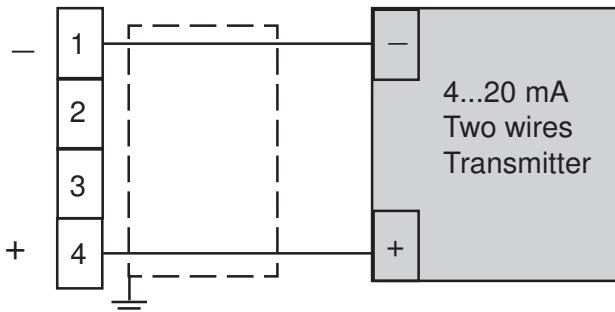

Fig. 8- 0/4-20 mA input wiring for passive transmitter using auxiliary pws

Input impedance: < 51 Ω.

Accuracy : 0.5 % of Span + 1 dgt @ 25 °C.

Protection: NOT protected from short circuit.

Internal auxiliary PWS: 10 V DC (± 10%), 20 mA max.

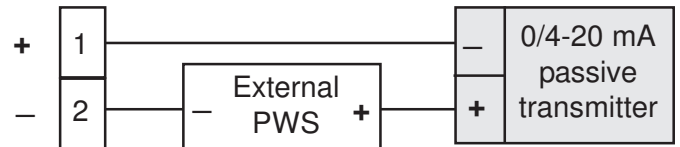

Fig. 9- 0/4-20 mA input wiring for passive transmitter using an external pws

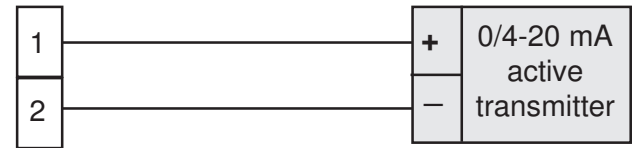
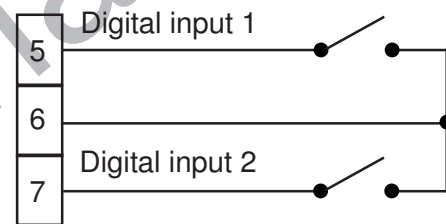

Fig. 10- 0/4-20 mA input wiring for active transmitter

2.9 LOGIC INPUTS

Safety notes:

- 1) Do not run logic input wiring together with power cables.
- 2) Use an external dry contact capable to switch 0.5 mA, 5 V DC.
- 3) The instrument needs 150 ms to recognize a contact status variation.
- 4) The logic inputs are **NOT** isolated by the measuring input. A double or reinforced isolation between logic inputs and power line must be assured by the external elements



2.10 OUTPUTS

Safety notes:

- 1) To avoid electrical shock, connect power line at last.
- 2) For supply connections use No 16 AWG or larger wires rated for at last 75 °C.
- 3) Use copper conductors only.
- 4) SSR outputs are not isolated. A reinforced isolation must be assured by the external solid state relays.

a) OUT 1

Relay

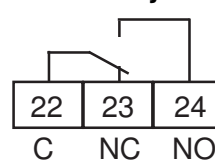

SSR

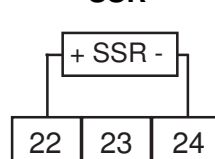

Out 1 contact rating:

8 A / 250 V cos φ = 1

3 A / 250 V cos φ = 0,4

Operation: 1 x 10⁵

Logic level 0:

V_{out} < 0.5 V DC

Logic level 1:

12 V ± 20% @ 1 mA

10 V ± 20% @ 20 mA

NOTE: This output is not isolated. A double or reinforced isolation between instrument output and power supply must be assured by the external solid state relay.

b) OUT 2

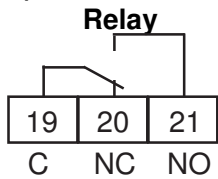

Out 2 contact rating:
 8 A /250 V $\cos\phi = 1$
 3 A /250 V $\cos\phi = 0.4$
Operation: 1×10^5

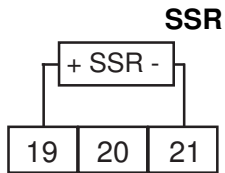

Logic level 0:
 $V_{out} < 0.5 \text{ V DC}$
Logic level 1:
 $12 \text{ V} \pm 20\% @ 1 \text{ mA}$
 $10 \text{ V} \pm 20\% @ 20 \text{ mA}$

NOTE: This output is not isolated. A double or reinforced isolation between instrument output and power supply must be assured by the external solid state relay.

c) OUT 3

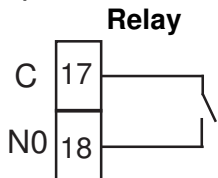

Out 3 contact rating:
 - 8 A /250 V $\cos\phi = 1$
 - 3 A /250 V $\cos\phi = 0.4$
Operation: 1×10^5

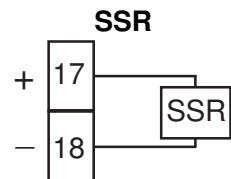

Logic level 0:
 $V_{out} < 0.5 \text{ V DC}$
Logic level 1:
 $12 \text{ V} \pm 20\% @ 1 \text{ mA}$
 $10 \text{ V} \pm 20\% @ 20 \text{ mA}$

NOTE: This output is not isolated. A double or reinforced isolation between instrument output and power supply must be assured by the external solid state relay.

d) OUT 4

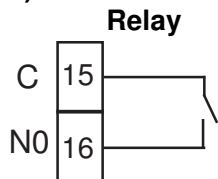

Out 3 contact rating:
 8 A /250 V $\cos\phi = 1$
 3 A /250 V $\cos\phi = 0.4$
Operation: 1×10^5

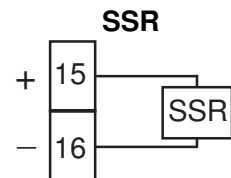

Logic level 0:
 $V_{out} < 0.5 \text{ V DC}$
Logic level 1:
 $12 \text{ V} \pm 20\% @ 1 \text{ mA}$
 $10 \text{ V} \pm 20\% @ 20 \text{ mA}$

NOTE: This output is not isolated. A double or reinforced isolation between instrument output and power supply must be assured by the external solid state relay.

e) OUT 5

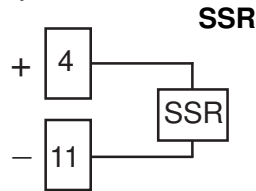

Logic level 0:
 $V_{out} < 0.5 \text{ V DC}$
Logic level 1:
 $12 \text{ V} \pm 20\% @ 1 \text{ mA}$
 $10 \text{ V} \pm 20\% @ 20 \text{ mA}$

NOTE: This output is not isolated. A double or reinforced isolation between instrument output and power supply must be assured by the external solid state relay.

2.11 SERIAL INTERFACE

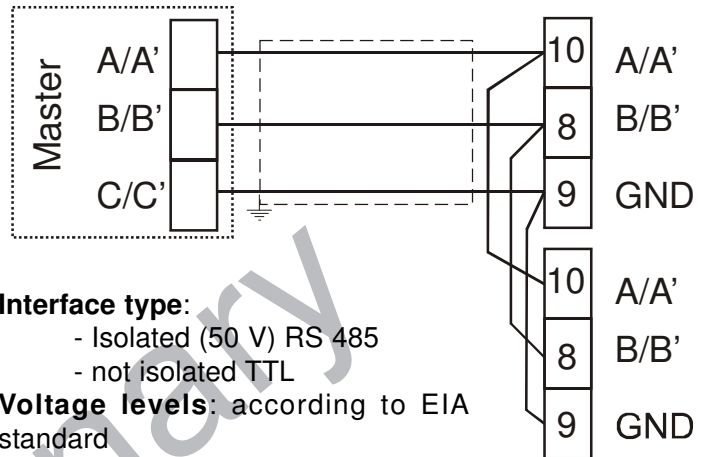

Interface type:

- Isolated (50 V) RS 485
- not isolated TTL

Voltage levels: according to EIA standard

Protocol type: MODBUS RTU.

Byte format: 8 bit without parity

Stop bit: one.

Baud rate: programmable from 1200 to 38400 baud

Address: programmable from 1 to 255

NOTES:

- 1) RS-485 interface allows to connect up to 30 devices with one remote master unit.
- 2) The cable length must not exceed 1.5 km at 9600 BAUD.
- 3) Follows the description of the signal sense of the voltage appearing across the interconnection cable as defined by EIA for RS-485.
 - a) The "A" terminal of the generator shall be negative with respect to the "B" terminal for a binary 1 (MARK or OFF) state.
 - b) The "A" terminal of the generator shall be positive with respect to the "B" terminal for a binary 0 (SPACE or ON).
- 4) This instrument allows to set serial link parameters (address and baud rate) in two different way:
 - A) Programmable parameters: all dipswitchs present in the back side of the instrument must be set to OFF.



The instrument will use the values programmed in [134] Add and [135] bAud parameters.

3. TECHNICAL CHARACTERISTICS

3.1 TECHNICAL SPECIFICATIONS

Case: Plastic, self-extinguishing degree: V-0 according to UL 94.

Front protection: IP 65 (when the optional panel gasket is mounted) for indoor locations according to EN 60070-1.

Rear terminals protection: IP 20 according to EN 60070-1.

Installation: Panel mounting

Terminal block: 24 screw terminals (screw M3, for cables from ϕ 0.25 to ϕ 2.5 mm² or from AWG 22 to AWG 14) with connection diagrams.

Dimensions: 75 x 33 mm, depth 75,5 mm

Cutout: 71 (-0 a + 0,5 mm) x 29 (-0 a + 0,5 mm)

Weight: 180 g max.

Power supply:

- 100 to 240 VAC (\pm 10 % of the nominal value)
- 24 V AC/DC (\pm 10 % of the nominal value)..

Power consumption: 5 VA max.

Insulation voltage:

2300 V rms according to EN 61010-1.

Display: one 4 digits red display h 12 mm + 3 LED Bargraph.

Display updating time: 500 ms.

Sampling time: 130 ms.

Resolution: 30000 counts.

Total Accuracy: \pm 0.5% F.S.V. \pm 1 digit @ 25°C of room temperature.

Common mode rejection: 120 dB at 50/60 Hz.

Normal mode rejection: 60 dB at 50/60 Hz.

Electromagnetic compatibility and safety requirements:

Compliance: directive EMC 2004/108/CE (EN 61326), directive LV 2006/95/CE (EN 61010-1)

Installation category: II

Pollution category: 2

Temperature drift: It is part of the global accuracy.

Operating temperature: from 0 to 50°C (from 32 to 122°F).

Storage temperature: -30 to +70°C (-22 to 158°F)

Humidity: from 20 % to 85% RH, non condensing.

Protections: WATCH DOG (hardware/software) for the automatic restart.

B) Fixed parameters: the dipswitches present in the back side of the instrument must be set according to the following table:

Dipswitch	Function
1	Address bit 0
2	Address bit 1
3	Address bit 2
4	Address bit 3
5	Address bit 4
6	Address bit 5
7	Baudrate bit 0
8	Baudrate bit 1

In other words:

- the address is 6 bit binary word and it use a standard codification. Example: the address 23 will be setted by setting equal to 1 the switches 5, 3, 2 and 1 ($16 + 4 + 2 + 1 = 23$)

- the baud rate is a 2 bit binary word but its values is described by the following table

Switch 7	Switch 8	Baud rate
OFF	OFF	2400
ON	OFF	9600
OFF	ON	19200
ON	ON	38400

Parameters [134] Add and [135] bAud become read only.

2.12 POWER SUPPLY

Power consumption: 5 W max.

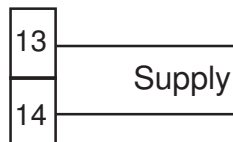

Supply voltage:
from 100 to 240 V AC (\pm 10%)

NOTES:

- 1) Before connecting the instrument to the power line, make sure that line voltage is equal to the voltage shown on the identification label.
- 2) To avoid electrical shock, connect power line at the end of the wiring procedure.
- 3) For supply connections use No 16 AWG or larger wires rated for at last 75 °C.
- 4) Use copper conductors only.
- 5) The power supply input is **NOT** fuse protected. Please, provide a T type 1A, 250 V fuse externally.

3.2 - HOW TO ORDER

Model

K30 - = Regulator

K30T = Regulator + timer

K30P = Regulator + timer + programmer

Power supply

L = 24 V AC/DC (under development)

H = 100 to 240 V AC

Input / 2 Digital Inputs (standard)

C = J, K, R, S, T, PT100, 0/12...60 mV

E = J, K, R, S, T, PTC, NTC, 0/12...60mV

I = 0/4...20 mA

V = 0...1V, 0/1...5V, 0/2...10V

Out 1 / Out 5 SSR (standard)

R = Relay SPDT 8A on resistive load

O = VDC for SSR

Out 2

- = Not available

R = Relay SPDT 8A on resistive load

O = VDC for SSR

Out 3

- = Not available

R = Relay SPST-NO 5A on res. load

O = VDC for SSR

Out 4

- = Not available

R = Relay SPST-NO 5A, res. load

O = VDC for SSR

Communication

- = TTL Modbus

S = RS 485 amd TTL ModBus



4. CONFIGURATION PROCEDURE

4.0 General notes about K30

The K 30 is a blind controller (without display and keyboard) but it is equipped with two serial links.

The first serial link is an RS485 and it is designed for a standard dialogue with a master unit (a supervisor, an HMI, a PLC, etc).

The second serial link (TTL type) is used to dialogue with a remote display.

The remote display can be equipped with one or two rows - four digits display and a 4 keys keyboard.

All actions can be made by remote display or by serial link.

The actions made by serial link are not submitted to time-out or password, have an immediate effect and do not produces any visualization.

On the contrary, the actions made by remote display (and keyboard) follows the same "strategy" of the front panel instrument of this series.

In the following pages we will describe all possible actions that you can do by a remote display.

We have selected the single display type.

The only differences you will see using a double display are in the possibility to see two value at the same time instead of one alternately to the second (e.g. a parameter code alternately with its value).

4.1 Introduction

When the instrument is powered, it starts immediately to work according to the parameters values loaded in its memory.

The instrument behaviour and its performances are governed by the value of the memorized parameters.

At the first start up the instrument will use a "default" parameter set (factory parameter set); this set is a generic one (e.g. a TC J input is programmed).

We recommend that you modify the parameter set to suit your application (e.g. set the right input type, Control strategy, define an alarm, etc.)

To change these parameters you will need to enter the "Configuration procedure".

4.1.1 Access levels to the parameter modifications and their password

The instrument have one complete parameter set.

We call this set "configuration parameter set" (or "configuration parameters").

The access to the configuration parameters is protected by a programmable password (password level 3).

The configuration parameters are collected in various groups. Every group defines all parameters related with a specific function (E.g. control, alarms, output functions).

Note the instrument will show only the parameters consistent with the specific hardware and in

accordance with the value assigned to the previous parameters (e.g. if you set an output as "not used" the instrument will mask all other parameters related with this output).

4.2 INSTRUMENT BEHAVIOUR AT POWER UP

At power up the instrument can start in one of the following mode depending on its configuration:

Auto mode without program functions

- The display will show the measured value
- The decimal figure of the less significant digit is OFF
- The instrument is performing the standard closed loop control.

Manual mode (OPLO)

- The display will show alternately the measured value and the message <<OPLO>>.
- The instrument does not perform Automatic control
- The control output is equal to 0% and can be manually modified by ▲ and ▼ buttons.

Stand by mode (St.bY)

- The display will show alternately the measured value and the message <<St.bY>> or <<od>>.
- The instrument does not perform any control (the control outputs are OFF).
- The instrument is working as an indicator.

Auto mode with automatic program start up

- The display will show one of the following information:
 - the measured value
 - the operative set point (when it is performing a ramp)
 - the time of the segment in progress (when it is performing a soak).
 - the measured value alternate with the message <<St.bY>>.
- In all cases, the decimal figure of the less significant digit is lit.

We define all the above described conditions as "Standard Display".

4.3. HOW TO ENTER INTO THE CONFIGURATION MODE

- 1) Push the P button for more than 3 seconds.
The display will show alternately 0 and << PASS >>.
- 2) Using ▲ and/or ▼ buttons set the programmed password.

NOTES:

- a) The factory default password for configuration parameters is equal to 30.
- b) All parameter modification are protected by a time out. If no button is pressed for more than 10 second the instrument return automatically back to the Standard display, the new value of the last selected parameter is lost and the parameter modification

procedure is closed.

When you desire to remove the time out (e.g. for the first configuration of an instrument) you can use a password equal to 1000 plus the programmed password (e.g. 1000 + 30 [default] = 1030).

It is always possible to end manually the parameter configuration procedure (see the next paragraph).

- c) During parameter modification the instrument continue to perform the control.

In certain conditions, when a configuration change can produce a heavy bump to the process, it is advisable to temporarily stop the controller from controlling during the programming procedure (its control output will be Off)

A password equal to 2000 + the programmed value (e.g. 2000 + 30 = 2030).

The control will restart automatically when the configuration procedure will be manually closed.

- 3) Push the P button

If the password is correct the display will show the acronym of the first parameter group preceded by the

symbol  .

In other words the display will show  .

The instrument is in configuration mode.

4.4. HOW TO EXIT FROM THE CONFIGURATION MODE

Push  button for more than 5 seconds.

The instrument will come back to the “standard display”

4.5. KEYBOARD FUNCTION DURING PARAMETER MODIFICATION

 A short press allows you to exit from the current parameter group and select a new parameter group.

A long press allows you to close the configuration parameter procedure (the instrument will come back to the “standard display”).

 When the display is showing a group, It allows you to enter in the selected group.

When the display is showing a parameter, it allows you to memorize the selected value and to go to the next parameter within the same group.

 it allows you to increase the value of the selected parameter

 it allows you to decrease the value of the selected parameter

NOTE: The group selection is cyclic as well as the selection of the parameters in a group.



4.6. FACTORY RESET - DEFAULT PARAMETERS LOADING PROCEDURE

Some times, e.g. when you re-configure an instrument previously used for other works or from other people or when you have made too many errors during configuration and you decided to re-configure the instrument, it is possible to restore the factory configuration.

This action allows you to put the instrument in a defined condition (in the same condition it was at the first power up).

The default data are the typical values loaded in the instrument prior to shipment from factory.

To load the factory default parameter set, proceed as follows:

- 1) Press the P button for more than 5 seconds
- 2) The display will show alternately “PASS” and “0”.
- 3) By  and  button set the value -481.
- 4) Push P button.
- 5) The instrument will turn OFF all LEDs then it will show “dFLt” messages and than it turn ON all LEDs of the display for 2 seconds and than it will restart as for a new power up.

The procedure is complete.

Note: the complete list of the default parameter is available in Appendix A.

4.7. ALL CONFIGURATION PARAMETERS

In the following pages we will describe all the parameters of the instrument. However, the instrument will only show the parameters applicable to its hardware options in accordance with the specific instrument configuration (i.e. setting AL1t [Alarm 1 type] equal to <<nonE>> [not used], all parameters related with the alarm 1 will be skipped).

inP GROUP - Main and auxiliary input configuration

[2] SEnS - Input type

Available: Always

Range:

When the code of the input type is equal to C (see Ordering Code at page 29)

J	= TC J	(0 to 1000 °C/ 32 to 1832 °F)
crAL	= TC K	(0 to 1370 °C/ 32 to 2498 °F)
S	= TC S	(0 to 1760 °C/ 32 to 3200 °F)
r	= TC R	(0 to 1760 °C/ 32 to 3200 °F)
t	= TC T	(0 to 400 °C/ 32 to 752 °F)
ir.J	= Exergen IRS J	(0 to 1000 °C/ 32 to 1832 °F)
ir.cA	= Exergen IRS K	(0 to 1370 °C/ 32 to 2498 °F)
Pt1	= RTD Pt 100	(-200 to 850 °C/-328 to 1562 °F)
0.50	= 0 to 50 mV linear	
0.60	= 0 to 60 mV linear	
12.60	= 12 to 60 mV linear	

When the code of the input type is equal to E

J	= TC J	(0 to 1000 °C/ 32 to 1832 °F)
crAL	= TC K	(0 to 1370 °C/ 32 to 2498 °F)

S	= TC S	(0 to 1760 °C/ 32 to 3200 °F)
r	= TC R	(0 to 1760 °C/ 32 to 3200 °F)
t	= TC T	(0 to 400 °C/ 32 to 752 °F)
ir.J	= Exergen IRS J	(0 to 1000 °C/ 32 to 1832 °F)
ir.cA	= Exergen IRS K	(0 to 1370 °C/ 32 to 2498 °F)
Ptc	= PTC KTY81-121	(-55 to 150 °C/-67 to 302 °F)
ntc	= NTC 103-AT2	(-50 to 110 °C/-58 to 230 °F)
0.50	= 0 to 50 mV linear	
0.60	= 0 to 60 mV linear	
12.60	= 12 to 60 mV linear	

When the code of the input type is equal to I

0.20	= 0 to 20 mA linear
4.20	= 4 to 20 mA linear

When the code of the input type is equal to V

0.1	= 0 to 1 V linear
0.5	= 0 to 5 V linear
1.5	= 1 to 5 V linear
0.10	= 0 to 10 V linear
2.10	= 2 to 10 V linear

Note:

- When a TC input is selected and a decimal figure is programmed (see the next parameter) the maximum displayed value become 999.9 °C or 999.9 °F.
- **Every** change of the SEnS parameter setting will force the following change:

[3] dP	= 0
[129] ES.L	= -1999
[130] ES.H	= 9999

[3] dP - Decimal point position

Available: Always

Range:

When [2] SenS = Linear input: 0 to 3.
 When [2] SenS different from linear input: 0 or 1

Note: Every change of the dP parameter setting will produce a change of the parameters related with it (e.g. set points, proportional band, etc.)

[4] SSc – Initial scale read-out for linear inputs

Available: when a linear input is selected by [2] SenS.

Range: -1999 to 9999

Notes:

- It allows the scaling of the analogue input to set the minimum displayed/measured value
 The instrument will show a measured value up to 5% less than SSc value and then it will show an underrange error.
- It is possible to set a initial scale read-out higher than the full scale read-out in order to obtain a reverse read-out scaling
 E.g. 0 mA = 0 mBar and 20 mA = - 1000 mBar (vacuum).

[5] FSc - Full scale read-out for linear input

Available: when a linear input is selected by [2] SenS.

Range: -1999 to 9999

Notes:

- It allows the scaling of the analogue input to set the maximum displayed/measured value
 The instrument will show a measured value up to 5% higher than [5] FSc value and then it will show an overrange error.
- It is possible to set a full scale read-out lower than the initial scale read-out in order to obtain a reverse read-out scaling
 E.g. 0 mA = 0 mBar and 20 mA = - 1000 mBar (vacuum).

[6] unit - Engineering unit

Available: when a temperature sensor is selected by [2] SenS parameter.

Range:

°c	= Centigrade
°F	= Fahrenheit

[7] FiL - Digital filter on the measured value

Available: Always

Range: oFF (No filter) 0.1 to 20.0 s

Note: this is a first order digital filter applied on the measured value. For this reason it will affect both the measured value but also the control action and the alarms behaviour.

[8] inE - Selection of the Sensor Out of Range type that will enable the safety output value.

Available: Always

Range:

- our = when an **overrange** or an **underrange** is detected, the power output will be forced to the value of [9] oPE parameter.
- or = when an **overrange** is detected, the power output will be forced to the value of [9] oPE parameter.
- ur = when an **underrange** is detected, the power output will be forced to the value of [9] oPE parameter.

[9] oPE - Safety output value

Available: Ever

Range: -100 to 100 % (of the output).

Notes:

- When the instrument is programmed with one control action only (heat or cool), setting a value outside of the available output range, the instrument will use Zero.
 E.g. when heat action only has been programmed, and oPE is equal to -50% (cooling) the instrument will use the zero value.
- When ON/OFF control is programmed and an out of range is detected, the instrument will perform the safety output value using a fixed cycle time equal to 20 seconds.

[10] diF1 - Digital input 1 function

Available: when the instrument is equipped with digital inputs.

Range:

- oFF = No function
- 1 = Alarm Reset [status]
- 2 = Alarm acknowledge (ACK) [status].
- 3 = Hold of the measured value [status].
- 4 = Stand by mode of the instrument [status]
When the contact is closed the instrument operates in stand by mode.
- 5 = HEAt with SP1 and Cool with "SP2" [status] (see "Note about digital inputs")
- 6 = Timer Run/Hold/Reset [transition]
Short closure allows to start timer execution and to suspend it while a long closure (longer than 10 seconds) allows to reset the timer.
- 7 = Timer Run [transition] a short closure allows to start timer execution.
- 8 = Timer rese [transition] a short closure allows to reset timer count.
- 9 = Timer run/hold [Status]
- Contact closure = timer RUN
- contact open = timer Hold
- 10 = Program Run [transition]
The first closure allows to start program execution but a second closure **restart** the program execution from the beginning.
- 11 = Program Reset [transition]
A contact closure allows to reset program execution.
- 12 = Program Hold [transition]
The first closure allows to hold program execution and a second closure continue program execution.
- 13 = Program Run/Hold [status]
When the contact is closed the program is running.
- 14 = Program Run/Reset [status]
Contact closed - Program run
Contact open - Program reset
- 15 = Instrument in Manual mode (Open Loop) [status]
- 16 = Sequential set point selection [transition] (see "Note about digital inputs")
- 17 = SP1 / SP2 selection [status]
- 18 = Binary selection of the set point made by digital input 1 (less significant bit) and digital input 2 (most significant bit) [status].
- 19 = Digital input 1 will work in parallel to the ▲ button while digital input 2 will work in parallel to the ▼ button.

[11] diF2 - Digital input 2 function

Available: when the instrument is equipped with digital inputs.

Range:

- oFF = No function
- 1 = Alarm Reset [status]
- 2 = Alarm acknowledge (ACK) [status].

- 3 = Hold of the measured value [status].
- 4 = Stand by mode of the instrument [status]
When the contact is closed the instrument operates in stand by mode.
- 5 = HEAt with SP1 and Cool with "SP2" [status] (see "Note about digital inputs")
- 6 = Timer Run/Hold/Reset [transition]
Short closure allows to start timer execution and to suspend it while a long closure (longer than 10 seconds) allows to reset the timer.
- 7 = Timer Run [transition] a short closure allows to start timer execution.
- 8 = Timer rese [transition] a short closure allows to reset timer count.
- 9 = Timer run/hold [Status]
- Contact closure = timer RUN
- contact open = timer Hold
- 10 = Program Run [transition]
The first closure allows to start program execution but a second closure **restart** the program execution from the beginning.
- 11 = Program Reset [transition]
A contact closure allows to reset program execution.
- 12 = Program Hold [transition]
The first closure allows to hold program execution and a second closure continue program execution.
- 13 = Program Run/Hold [status]
When the contact is closed the program is running.
- 14 = Program Run/Reset [status]
Contact closed - Program run
Contact open - Program reset
- 15 = Instrument in Manual mode (Open Loop) [status]
- 16 = Sequential set point selection [transition] (see "Note about digital inputs")
- 17 = SP1 / SP2 selection [status]
- 18 = Binary selection of the set point made by digital input 1 (less significant bit) and digital input 2 (most significant bit) [status].
- 18 = Digital input 1 will work in parallel to the ▲ button while digital input 2 will work in parallel to the ▼ button.

Notes about digital inputs

- 1) When diF1 or diF2 (e.g. diF1) are equal to 5 the instrument operates as follows:
 - when the contact is open, the control action is an heating action and the active set point is SP1.
 - when the contact is closed, the control action is a cooling action and the active set point is SP2.
- 2) When diF1 is equal to 18, diF2 setting is forced to 18 and diF2 value and cannot perform another additional function.
- 3) When diF1 and diF2 are equal to 18, the set point selection will be in accordance with the following table

Dig In1	dig.In2	Operative set point
Off	Off	= Set point 1
On	Off	= Set point 2
Off	On	= Set point 3
On	On	= Set point 4

- 4) When diF1 is equal to 19, diF2 setting is forced to up.du and 19 value and cannot perform another additional function.
- 5) When a "Sequential set point selection" is used, every closure of the logic input increase the value of SPAT (active set point) of one step.
The selection is cyclic -> SP1 -> SP2 -> SP3 -> SP4

Output group - Output parameters

[12] o1F - Out 1 function

Available: Always

Range:

- nonE = Output not used. With this setting the status of the this output can be driven directly from serial link.
- H.rEG = Heating output
- c.rEG = Cooling output
- AL = Alarm output
- t.out = Timer output
- t.HoF = Timer out - OFF in Hold
- P.End = Program end indicator
- P.HLd = Program hold indicator
- P.uit = Program wait indicator
- P.run = Program run indicator
- P.Et1 = Program Event 1
- P.Et2 = Program Event 2
- or.bo = Out-of-range or burn out indicator
- P.FAL = Power failure indicator
- bo.PF = Out-of-range, burn out and Power failure indicator.
- diF.1 = The output repeats the digital input 1 status
- diF.2 = The output repeats the digital input 2 status
- St.bY = Stand By status indicator

Notes:

- When two or more outputs are programmed in the same way, these outputs will be driven in parallel.
- The power failure indicator will be reset when the instrument detect an alarm reset command by U key, digital input or serial link.
- When no control output is programmed, all the relative alarm (when present) will be forced to "nonE" (not used).

[13] o1.AL – Alarms linked up with the out 1

Available: when [12] o1F = AL

Range: 0 to 15 with the following rule.

- +1 = Alarm 1
- +2 = Alarm 2
- +4 = Alarm 3
- +8 = loop break alarm

Example 1: Setting 3 (2+1) the output will be driven by the alarm 1 and 2 (OR condition).

Example 2: Setting 13 (8+4+1) the output will be driven by alarm 1 + alarm 3 + loop break alarm.

[14] o1Ac – Output 1 action

Available: when [12] o1F is different from "nonE"

Range:

- dir = Direct action
- rEV = Reverse action
- dir.r = Direct action with revers LED indication
- rEV.r = Reverse action with reverse LED indication.

Notes:

- Direct action: the output repeats the status of the driven element.
Example: the output is an alarm output with direct action. When the alarm is **ON**, the relay will be energized (logic output 1).
- Reverse action: the output status is the opposite of the status of the driven element.
Example: the output is an alarm output with reverse action. When the alarm is **OFF**, the relay will be energized (logic output 1). This setting is usually named "fail-safe" and it is generally used in dangerous process in order to generate an alarm when the instrument power supply goes OFF or the internal watchdog starts.

[15] o2F - Out 2 function

Available: When the instrument has out 2 option.

Range:

- nonE = Output not used. With this setting the status of the this output can be driven directly from serial link.
- H.rEG = Heating output
- c.rEG = Cooling output
- AL = Alarm output
- t.out = Timer output
- t.HoF = Timr out - OFF in Hold
- P.End = Program end indicator
- P.HLd = Program hold indicator
- P.uit = Program wait indicator
- P.run = Program run indicator
- P.Et1 = Program Event 1
- P.Et2 = Program Event 2
- or.bo = Out-of-range or burn out indicator
- P.FAL = Power failure indicator
- bo.PF = Out-of-range, burn out and Power failure indicator.
- diF.1 = The output repeats the digital input 1 status
- diF.2 = The output repeats the digital input 2 status
- St.By = Stand By status indicator

For other details see [12] O1F parameter

[16] o2.AL – Alarms linked up with Out 2

Available: when [15] o2F = AL

Range: 0 to 15 with the following rule.

- +1 = Alarm 1
- +2 = Alarm 2
- +4 = Alarm 3
- +8 = loop break alarm

For more details see [13] o1.AL parameter

[17] o2Ac – Output 2 action

Available: when [15] o2F is different from “nonE”

Range:

- dir = Direct action
- rEV = Reverse action
- dir.r = Direct action with revers LED indication
- rEv.r = Reverse action with reverse LED indication.

For more details see [14] o1.Ac parameter.

[18] o3F - Out 3 function

Available: When the instrument has out 3 option

Range:

- nonE = Output not used. With this setting the status of the this output can be driven directly from serial link.
- H.rEG = Heating output
- c.rEG = Cooling output
- AL = Alarm output
- t.out = Timer output
- t.HoF = Timr out - OFF in Hold
- P.End = Program end indicator
- P.HLd = Program hold indicator
- P. uit = Program wait indicator
- P.run = Program run indicator
- P.Et1 = Program Event 1
- P.Et2 = Program Event 2
- or.bo = Out-of-range or burn out indicator
- P.FAL = Power failure indicator
- bo.PF = Out-of-range, burn out and Power failure indicator.
- diF.1 = The output repeats the digital input 1 status
- diF.2 = The output repeats the digital input 2 status
- St.By = Stand By status indicator

For other details see [12] O1F parameter.

[19] o3.AL – Alarms linked up with Out 3

Available: when [18] o3F = AL

Range: 0 to 15 with the following rule.

- +1 = Alarm 1
- +2 = Alarm 2
- +4 = Alarm 3
- +8 = loop break alarm

For more details see [13] o1.AL parameter

[20] o3Ac – Output 3 action

Available: when [18] o3F is different from “nonE”

Range:

- dir = Direct action
- rEV = Reverse action
- dir.r = Direct action with revers LED indication
- rEV.r = Reverse action with reverse LED indication.

For more details see [14] o1.Ac parameter.

[21] o4F - Out 4 function

Available: When the instrument has out 4 option

Range:

nonE = Output not used. With this setting the status of the this output can be driven directly from serial link.

H.rEG = Heating output

c.rEG = Cooling output

AL = Alarm output

t.out = Timer output

t.HoF = Timr out - OFF in Hold

P.End = Program end indicator

P.HLd = Program hold indicator

P. uit = Program wait indicator

P.run = Program run indicator

P.Et1 = Program Event 1

P.Et2 = Program Event 2

or.bo = Out-of-range or burn out indicator

P.FAL = Power failure indicator

bo.PF = Out-of-range, burn out and Power failure indicator.

diF.1 = The output repeats the digital input 1 status

diF.2 = The output repeats the digital input 2 status

St.By = Stand By status indicator

For other details see [12] O1F parameter.

[22] o4.AL – Alarms linked up with Out 4

Available: when [21] o4F = AL

Range: 0 to 15 with the following rule.

+1 = Alarm 1

+2 = Alarm 2

+4 = Alarm 3

+8 = loop break alarm

For more details see [13] o1.AL parameter

[23] o4Ac – Output 4 action

Available: when [21] o4F is different from “nonE”

Range:

dir = Direct action

rEV = Reverse action

dir.r = Direct action with revers LED indication

rEV.r = Reverse action with reverse LED indication.

For more details see [14] o1.Ac parameter.

[24] o5F - Out 4 function

Available: Always

Range:

nonE = Output not used. With this setting the status of the this output can be driven directly from serial link.

H.rEG = Heating output

c.rEG = Cooling output

AL = Alarm output

t.out = Timer output

t.HoF = Timr out - OFF in Hold

P.End = Program end indicator

P.HLd = Program hold indicator

P. uit = Program wait indicator

P.run = Program run indicator

P.Et1 = Program Event 1

P.Et2 = Program Event 2

or.bo = Out-of-range or burn out indicator
 P.FAL = Power failure indicator
 bo.PF = Out-of-range, burn out and Power failure indicator.

diF.1 = The output repeats the digital input 1 status
 diF.2 = The output repeats the digital input 2 status
 St.By = Stand By status indicator

For other details see [12] O1F parameter.

[25] o5.AL – Alarms linked up with Out 5

Available: when [24] o5F = AL

Range: 0 to 15 with the following rule.

- +1 = Alarm 1
- +2 = Alarm 2
- +4 = Alarm 3
- +8 = loop break alarm

For more details see [13] o1.AL parameter

[26] o5Ac – Output 5 action

Available: when [24] o5F is different from “nonE”

Range:

- dir = Direct action
- rEV = Reverse action
- dir.r = Direct action with revers LED indication
- rEV.r = Reverse action with reverse LED indication.

For more details see [14] o1.Ac parameter.

AL1 Group - Alarm 1 parameters

[27] AL1t - Alarm 1 type

Available: Always

Range:

When one or more outputs are programmed as control output

- nonE = Alarm not used
- LoAb = Absolute low alarm
- HiAb = Absolute high alarm
- LHAb = Absolute band alarm
- LodE = Deviation low alarm (relative)
- HidE = Deviation high alarm (relative)
- LHdE = Relative band alarm.

When no output is programmed as control output

- nonE = Alarm not used
- LoAb = Absolute low alarm
- HiAb = Absolute high alarm
- LHAb = Absolute band alarm

Notes:

- The relative and deviation alarms are “relative” to the operative set point value.

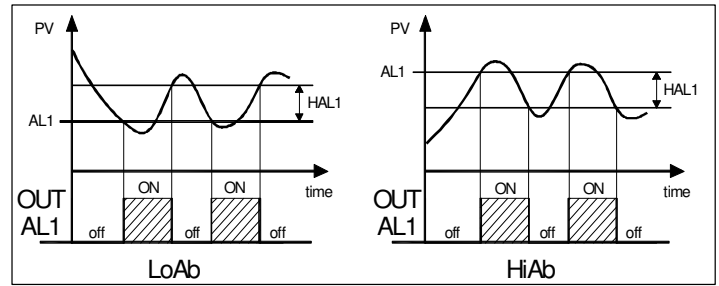
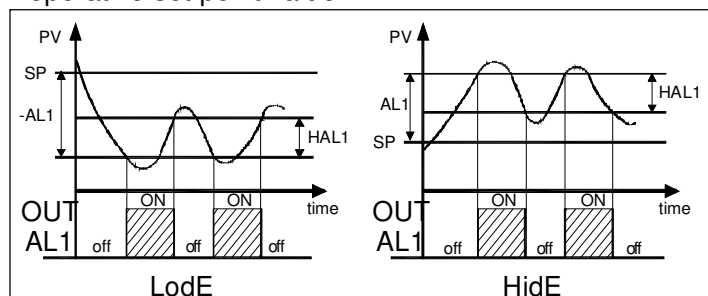

[28] Ab1 – Alarm 1 function

Available: when [27] AL1t is different from “nonE”

Range: 0 to 15 with the following rule:

- +1 = Not active at power up.
- +2 = Latched alarm (manual reset)
- +4 = Acknowledgeable alarm
- +8 = Relative alarm not active at set point change

Example: setting Ab1 equal to 5 (1+4) the alarm 1 will be “not active at power up” and “Acknowledgeable”.

Notes:

- The “not active at power up” selection allows you to inhibit the alarm function at instrument power up or when the instrument detects a transfer from manual mode (oplo) to auto mode
- Stand-by mode to auto mode.

The alarm will be automatically enabled when the measured value reaches, for the first time, the alarm threshold plus or minus the hysteresis (in other words, when the initial alarm condition disappears).

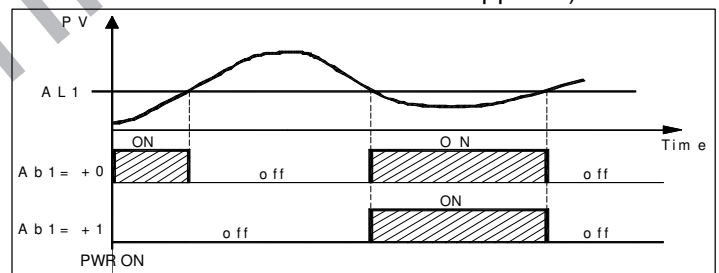

- A “Latched alarm” (manual reset) is an alarm that will remain active even if the conditions that generated the alarm no longer persist. Alarm reset can be done only by an external command (U button, digital inputs or serial link).

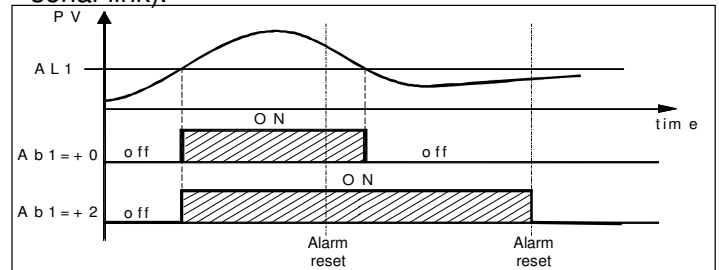

- An “Acknowledgeable” alarm is an alarm that can be reset even if the conditions that generated the alarm are still present. Alarm acknowledge can be done only by an external command (U button, digital inputs or serial link).

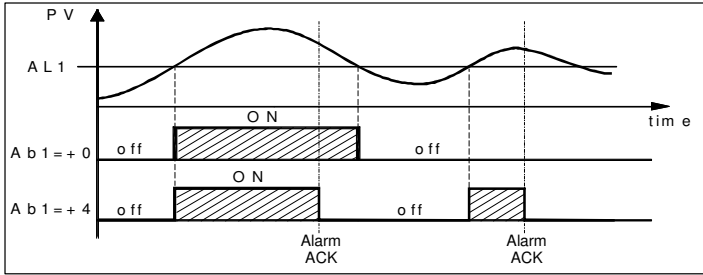

- A "relative alarm not active at set point change" is an alarm that masks the alarm condition after a set point change until process variable reaches the alarm threshold plus or minus hysteresis.

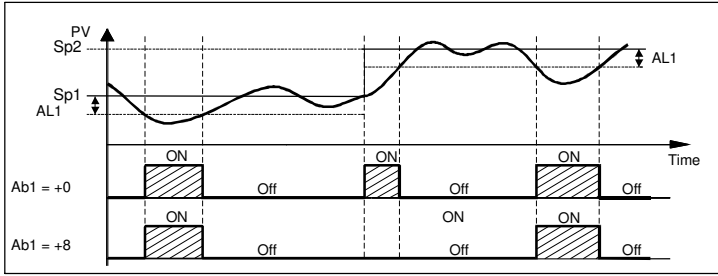

- The instrument does not memorize in EEPROM the alarm status. For this reason, the alarm status will be lost if a power down occurs.

[29] AL1L - For High and low alarms, it is the low limit of the AL1 threshold
 - For band alarm, it is low alarm threshold.

Available: when [27] AL1t is different from "nonE"
Range: from - 1999 to [30] AL1H engineering units.

[30] AL1H - For High and low alarms, it is the high limit of the AL1 threshold
 - For band alarm, it is high alarm threshold.

Available: when [27] AL1t is different from "nonE"
Range: from [29] AL1L to 9999 engineering units.

[31] AL1- Alarm 1 threshold

Available: when

- [27] AL1t = LoAb Absolute low alarm
- [27] AL1t = HiAb Absolute high alarm
- [27] AL1t = LodE Deviation low alarm (relative)
- [27] AL1t = LidE Deviation high alarm (relative)

Range: from [29] AL1L to [30] AL1H engineering units.

[32] HAL1 - Alarm 1 hysteresis

Available: when [27] AL1t is different to "nonE"

Range: from 1 to 9999 engineering units

Notes:

- The hysteresis value is the difference between the Alarm threshold value and the point the Alarm automatically resets.
- When the alarm threshold plus or minus the

hysteresis is out of input range, the instrument will not be able to reset the alarm.

Example: Input range from 0 to 1000 (mBar).

- set point equal to 900 (mBar)
- deviation low alarm equal to 50 (mBar)
- Hysteresis equal to 160 (mBar)

the theoretical reset point is $900 - 50 + 160 = 1010$ (mBar) but this value is out of range.

The reset can be made only by turning the instrument OFF, removing the condition that generate the alarm and than turn the instrument ON again.

- All band alarms use the same hysteresis value for both thresholds.
- When the hysteresis of a band alarm is bigger than the programmed band, the instrument will not be able to reset the alarm.

Example: Input range from 0 to 500 (°C).

- set point equal to 250 (°C)
- relative band alarm
- Low threshold equal to 10 (°C)
- High threshold equal to 10 (°C)
- Hysteresis equal to 25 (°C)

[33] AL1d – Alarm 1 delay

Available: when [27] AL1t different form "nonE"

Range: from oFF (0) to 9999 seconds

Note: The alarm goes ON only when the alarm condition persists for a time longer than [33] AL1d time but the reset is immediate.

[34] AL1o - Alarm 1 enabling during Stand-by mode

Available: when [27] AL1t different from "nonE"

Range:

- no = alarm 1 disabled during Stand by mode
- YES = alarm 1 enabled during Stand by mode

AL2 Group - Alarm 2 parameters

[35] AL2t - Alarm 2 type

Available: Always

Range:

When one or more outputs are programmed as control output

- nonE = Alarm not used
- LoAb = Absolute low alarm
- HiAb = Absolute high alarm
- LHAb = Absolute band alarm
- LodE = Deviation low alarm (relative)
- HidE = Deviation high alarm (relative)
- LHdE = Relative band alarm.

When no output is programmed as control output

- nonE = Alarm not used
- LoAb = Absolute low alarm
- HiAb = Absolute high alarm
- LHAb = Absolute band alarm

Notes: The relative alarm are “relative” to the current set point (this may be different to the Target setpoint if you are using the ramp to set point function).

[36] Ab2 – Alarm 2 function

Available: when [35] AL2t is different from “nonE”

Range: 0 to 15 with the following rule:

- +1 = Not active at power up.
- +2 = Latched alarm (manual reset)
- +4 = Acknowledgeable alarm
- +8 = Relative alarm not active at set point change

Example: setting Ad2 equal to 5 (1+4) the alarm 2 will be “not active at power up” and “Acknowledgeable”.

Notes: For other details see [28] Ab1 parameter.

[37] AL2L - For High and low alarms, it is the low limit of the AL2 threshold - For band alarm, it is low alarm threshold.

Available: when [35] AL2t is different from “nonE”

Range: from - 1999 to [38] AL2H engineering units.

[38] AL2H - For High and low alarms, it is the high limit of the AL2 threshold - For band alarm, it is high alarm threshold.

Available: when [35] AL2t is different from “nonE”

Range: from [37] AL2L to 9999 engineering units.

[39] AL2 - Alarm 2 threshold

Available: when

- [35] AL2t = LoAb Absolute low alarm
- [35] AL2t = HiAb Absolute high alarm
- [35] AL2t = LodE Deviation low alarm (relative)
- [35] AL2t = LidE Deviation high alarm (relative)

Range: from [37] AL2L to [38] AL2H engineering units.

[40] HAL2 - Alarm 2 hysteresis

Available: when [35] AL2t is different to “nonE”

Range: from 1 to 9999 engineering units

Notes: for other details see [32] HAL1 parameter

[41] AL2d – Alarm 2 delay

Available: when [32] AL2t different form “nonE”

Range: from oFF (0) to 9999 seconds

Note: The alarm goes ON only when the alarm condition persist for a time longer than [38] AL2d time but the reset is immediate.

[42] AL2o - Alarm 2 enabling during Stand-by mode

Available: when [35] AL2t different from “nonE”

Range:

- no = alarm 2 disabled during Stand by mode
- YES = alarm 2 enabled during Stand by mode

] AL3 Group - Alarm 3 parameters

[43] AL3t - Alarm 3 type

Available: Always

Range:

When one or more outputs are programmed as control output

- nonE = Alarm not used
- LoAb = Absolute low alarm
- HiAb = Absolute high alarm
- LHAb = Absolute band alarm
- LodE = Deviation low alarm (relative)
- HidE = Deviation high alarm (relative)
- LHdE = Relative band alarm.

When no output is programmed as control output

- nonE = Alarm not used
- LoAb = Absolute low alarm
- HiAb = Absolute high alarm
- LHAb = Absolute band alarm

Notes: The relative alarm are “relative” to the current set point (this may be different to the Target setpoint if you are using the ramp to set point function).

[44] Ab3 – Alarm 3 function

Available: when [43] AL3t is different from “nonE”

Range: 0 to 15 with the following rule:

- +1 = Not active at power up.
- +2 = Latched alarm (manual reset)
- +4 = Acknowledgeable alarm
- +8 = Relative alarm not active at set point change

Example: setting Ad3 equal to 5 (1+4) the alarm 3 will be “not active at power up” and “Acknowledgeable”.

Notes: For other details see [28] Ab1 parameter.

[45] AL3L - For High and low alarms, it is the low limit of the AL3 threshold - For band alarm, it is low alarm threshold.

Available: when [43] AL3t is different from “nonE”

Range: from - 1999 to [46] AL3H engineering units.

[46] AL3H - For High and low alarms, it is the high limit of the AL3 threshold - For band alarm, it is high alarm threshold.

Available: when [43] AL3t is different from “nonE”

Range: from [45] AL3L to 9999 engineering units.

[47] AL3 - Alarm 3 threshold

Available: when

- [43] AL3t = LoAb Absolute low alarm
- [43] AL3t = HiAb Absolute high alarm
- [43] AL3t = LodE Deviation low alarm (relative)
- [43] AL3t = LidE Deviation high alarm (relative)

Range: from [45] AL3L to [46] AL3H engineering units.

[48] HAL3 - Alarm 3 hysteresis

Available: when [43] AL3t is different to "nonE"

Range: from 1 to 9999 engineering units

Notes: for other details see [42] HAL1 parameter

[49] AL3d – Alarm 3 delay

Available: when [43] AL3t different form "nonE"

Range: from oFF (0) to 9999 seconds

Note: The alarm goes ON only when the alarm condition persist for a time longer than [49] AL3d time but the reset is immediate.

[50] AL3o - Alarm 3 enabling during Stand-by mode

Available: when [43] AL3t different from "nonE"

Range:

no = alarm 3 disabled during Stand by mode

YES = alarm 3 enabled during Stand by mode.

1 LbA group - Loop break alarm

General note about LBA alarm

The LBA operate as follows:

When you apply 100 % of the power output to a process, the process variable, after a time due to the process inertia, begins to change in a known direction (increases for an heating action or decreases for a cooling action).

Example: if I apply 100% of the power output to a furnace, the temperature must go up unless one of the component in the loop is faulty (heater, sensor, power supply, fuse, etc...)

The same philosophy can be applied to the minimum power. In our example, when I turn OFF the power to a furnaces, the temperature must go down, if not the SSR is in short circuit, the valve is jammed, etc..

LBA function is automatically enabled when the PID requires the maximum or the minimum power.

When the process response is slower than the programmed limit the instrument generates an alarm.

NOTES:

- When the instrument is in manual mode, the LBA function is disabled.
- When LBA alarm is ON the instrument continue to perform the standard control. If the process response come back into the programmed limit, the instrument reset automatically the LBA alarm.
- This function is available only when the programmed control algorithm is equal to PID (Cont = PID).

[51] LbAt - LBA time

Available: when [55] Cont = PID

Range: oFF = LBA not used or from 1 to 9999 seconds

[52] LbSt – Delta measure used by LBA during Soft start.

Available: when [51] LbAt is different from oFF

Range:

- oFF = loop break alarm is inhibit during soft start
- 1 to 9999 engineering units.

[53] LbAS – Delta measure used by loop break alarm (loop break alarm step)

Available: when [51] LbAt is different from oFF

Range: from 1 to 9999 engineering units.

[54] LbcA - Condition for LBA enabling

Available: when [51] LbAt is different from oFF

Range:

- uP = Enabled when the PID requires the maximum power only.
- dn = Enabled when the PID requires the minimum power only
- both = Enabled in both condition (when the PID requires the maximum or the minimum power).

LBA application example:

LbAt (LBA time) = 120 seconds (2 minutes)

LbAS (delta LBA) = 5 °C

The machine has been designed in order to reach 200 °C in 20 minutes (20°C/min).

When the PID demand 100 % power, the instrument starts the time count.

During time count if the measured value increases more than 5 °C, the instrument restarts the time count. Otherwise if the measured value does not reach the programmed delta (5 °C in 2 minutes) the instrument will generate the alarm.

1 rEG group - Control parameters

The rEG group will be available only when at least one output is programmed as control output (H.rEG or C.rEG).

[55] cont - Control type:

Available: when at least one output is programmed as control output (H.rEG or C.rEG).

Range:

When two control action (heat **and** cool) are programmed:

Pid = PID (heat **and** cool)

nr = Heat/Cool ON/OFF control with neutral zone

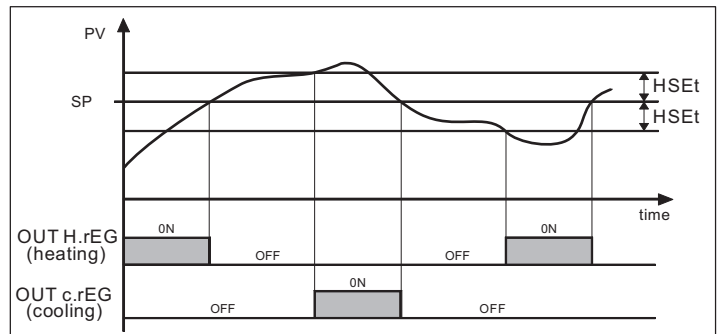

When one control action (heat **or** cool) is programmed:

Pid = PID (heat **or** cool)

On.FA = ON/OFF asymmetric hysteresis

On.FS = ON/OFF symmetric hysteresis

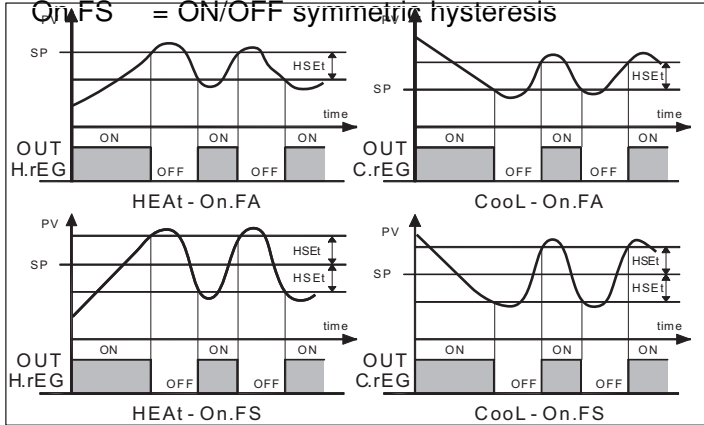

Note:

- ON/OFF control with asymmetric hysteresis :
 - OFF when $PV \geq SP$
 - ON when $PV \leq (SP - \text{hysteresis})$
- ON/OFF control with symmetric hysteresis :
 - OFF when $PV \geq (SP + \text{hysteresis})$
 - ON when $PV \leq (SP - \text{hysteresis})$

[56] Auto – Auto tune selection

Tecnologic has developed two auto-tune algorithms:

- 1) Oscillating auto-tune:
- 2) Fast auto-tune

- 1) The oscillating auto-tune is the usual auto-tune and:
 - it is more accurate
 - can start even if PV is close to the set point.
 - can be used even if the set point is close to the ambient temperature.

- 2) The fast type is suitable when:
 - The process is very slow and you want to be operative in a short time.
 - When an high overshoot is not acceptable.
 - In multi loop machinery where the fast method reduces the calculation error due to the effect of the other loops.

NOTE: fast auto-tune can start only when the measured value (PV) is lower than $(SP + 1/2SP)$.

Available: when [49] cont = PID

Range: from -4 to 4

where:

- 4 = Oscillating auto-tune with automatic restart at power up (after soft start) and after **all** set point change.
- 3 = Oscillating auto-tune with manual start.
- 2 = Oscillating auto-tune with automatic start at the first power up only.
- 1 = Oscillating auto-tune with automatic restart at every power up
- 0 = Not used
- 1 = Fast auto tuning with automatic restart at

- every power up
- 2 = Fast auto-tune with automatic start at the first power up only.
- 3 = FAST auto-tune with manual start
- 4 = FAST auto-tune with automatic restart at power up (after soft start) and after a set point change.

NOTE: The auto-tune is inhibited during program execution.

[57] Aut.r - Manual start of the auto-tune

Available: when [55] cont = PID

Range:

- oFF = the instrument is not performing the auto-tune
- on = the instrument is performing the auto-tune

[58] SELF - Self-tune enable

The self-tuning is an adaptive algorithm able to optimize continuously the PID parameter value. This algorithm is specifically designed for all process subjected to big load variation able to change heavily the process response.

Available: when [55] cont = PID

Range:

- oFF = the instrument is **not** performing the self-tune
- on = the instrument is performing the self-tune

[59] HSEt - Hysteresis of the ON/OFF control

Available: when [55] cont is different from PID.

Range: from 0 to 9999 engineering units.

[60] cPdt – Time for compressor protection

Available: when [55] cont = nr

Range:

- OFF = protection disabled
- From 1 to 9999 seconds.

[61] Pb - Proportional band

Available: When [55] cont = PID and [58] SELF = no

Range: from 1 to 9999 engineering units.

Note: auto-tune functions calculate this value.

[62] int - Integral time

Available: When [55] cont = PID and [58] SELF = no

Range:

- OFF = Integral action excluded
- from 1 to 9999 seconds
- inF= Integral action excluded

Note: auto-tune functions calculate this value.

[63] dEr - Derivative time

Available: When [55] cont = PID and [58] SELF = no

Range:

- oFF - derivative action excluded
- from 1 to 9999 seconds

Note: auto-tune functions calculate this value.

[64] Fuoc - Fuzzy overshoot control

This parameter reduces the overshoot usually present at instrument start up or after a set point change and it will be active only in this two cases.

Setting a value between 0.00 and 1.00 it is possible to slow down the instrument action during set point approach.

Setting Fuoc = 1 this function is disabled

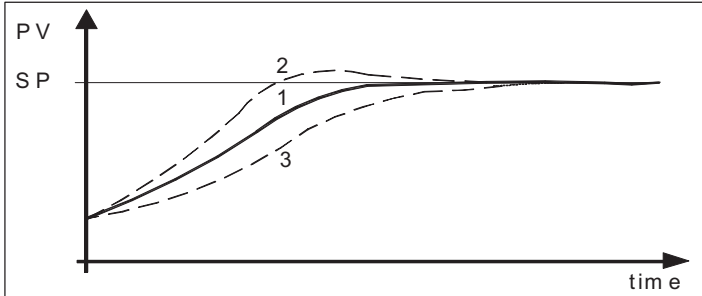

Available: When [55] cont = PID and [58] SELF = no

Range: from 0 to 2.00.

Note: fast auto-tune calculates the Fuoc parameter while the oscillating one sets it equal to 0.5.

[65] H.Act – Heating output (H.rEG) actuator

This parameter sets the minimum cycle time of the heating output.

It aims to respect the minimum cycle time of a specific actuator in order to assure a long actuator life.

Available: When at list one output is programmed in order to be the heating output (H.rEG), [55] cont = PID and [58] SELF = no

Range:

SSr = Solid state relay output

rELY = Relay or contactor

SLou = Slow actuator (e.g. burners)

Note: setting

- SSr no limit is applied to the [63] tcrH parameter and it is pre-set equal to 1 seconds
- rELY the [63] tcrH parameter is limited to 20 seconds and [63] tcrH is pre-set equal to 20 seconds
- SLou the [63] tcrH parameter is limited to 40 seconds and [63] tcrH is pre-set equal to 40 seconds

[66] tcrH - Cycle time of the heating output

Available: When at least one output is programmed in order to be the heating output (H.rEG), [55] cont = PID and [58] SELF = no

Range:

when [65] H.Act = SSr

from 1.0 to 130.0 seconds

when [65] H.Act = reLY

from 20,0 to 130.0 seconds

when [65] H.Act = SLou

from 40,0 to 130.0 second

[67] PrAt - Power ratio between heating and cooling action (relative cooling gain)

The instrument uses the same PID parameter set for heat and for cool action but the efficiency of the two actions are usually different.

This parameter allows to define the ratio between the efficiency of the heating system and the efficiency of the cooling one.

An example will help us to explain you the philosophy.

Consider one loop of a plastic extruder.

The working temperature is equal to 250 °C.

When you want to increase the temperature from 250 to 270 °C (delta 20 °C) using 100% of the heating power (resistor), you will need 60 seconds.

On the contrary, when you want to decrease the temperature from 250 to 230 °C (delta 20 °C) using 100% of the cooling power (fan), you will need 20 seconds only.

In our example the ratio is equal to $60/20 = 3$ ([63] PrAt = 3) and it say that the efficiency of the cooling system is 3 time more efficient of the heating one.

Available: When two control action are programmed (H.rEG and c.rEG) and [55] cont = PID and [58] SELF = no

Range: from 0.01 a 99.99

Note: auto-tune functions calculate this value.

[68] c.Act – Cooling output (C.rEG) actuator

Available: When at list one output is e programmed in order to be the cooling output (c.rEG), [55] cont = PID and [58] SELF = no

Range:

SSr = Solid state relay output

rELY = Relay or contactor

SLou = Slow actuator (e.g. compressors)

Note: for more details see [65] h.Act parameter

[69] tcrC - Cycle time of the cooling output

Available: When at least one output is e programmed in order to be the cooling output (c.rEG), [55] cont = PID and [58] SELF = no

Range:

when [65] H.Act = SSr

from 1.0 to 130.0 seconds

when [65] H.Act = reLY

from 20,0 to 130.0 seconds

when [65] H.Act = SLou

from 40,0 to 130.0 second

Note: auto-tune functions calculate this value.

[70] rS - Manual reset (integral pre-load)

It allows to drastically reduce the undershoot due to a hot restart.

When your process is steady, the instrument operates with a steady power output (e.g. 30%).

If a short power down occurs, the process restarts with a process variable close to the set point while the instrument starts with an integral action equal to zero.

Setting a manual reset equal to the average power output (in our example 30 %) the instrument will start with a power output equal to the value it will use at steady state (instead of zero) and the undershoot will become very little (in theory equal to zero).

Available: When [55] cont = PID and [58] SELF = no
Range: from -100.0 to 100.0 %

[71] roh.L - Minimum power for heating outputs

Available: When at list one output is e programmed in order to be the Heating output (H.rEG) and [58] cont = PID.

Range: from 0 to [72] roh.h %

[72] roh.h - Maximum power for heating outputs

Available: When at list one output is e programmed in order to be the Heating output (H.rEG) and [58] cont = PID.

Range: from [71] roh.L to 100 %

[73] roc.L - Minimum power for cooling outputs

Available: When at list one output is e programmed in order to be the cooling output (C.rEG) and [58] cont = PID.

Range: from 0 to [74] roc.h %

[74] roc.h - Maximum power for cooling output

Available: When at list one output is e programmed in order to be the cooling output (C.rEG) and [58] cont = PID.

Range: from [73] roc.L to 100 %

[75] oPSh - Heating output max rate of rise

Available: When at list one output is e programmed in order to be the Heating output (H.rEG) and [58] cont = PID.

Range: from 1 to 50%/s + inF = step transfer

[76] oPSc - Cooling output max rate of rise

Available: When at list one output is e programmed in order to be the cooling output (C.rEG) and [58] cont = PID.

Range: from 1 to 50%/s + inF = step transfer

GENERAL NOTES ABOUT SPLIT RANGE FUNCTION

The use of this function is only possible if the PID control is dual function and can be used to delay or bring forward the intervention of the actuators commanded by the instrument.

Using this function it is therefore possible to optimise the intervention of the two actuators in such a way that their actions do not overlap or so that they overlap so that they obtain the mix of the two actions of the actuators.

Basically, this means setting two power offsets (one for direct action and one for reverse action) that set the beginning of the intervention of the actuator commanded by the output.

The parameters that can be set for this function

contained in the block “JrEG”, are:

“thr1” : Power threshold at which output H.rEG begins to operate.

“thr2” : Power threshold at which output C.rEG begins to operate.

Basically, if one wishes to bring forward the reverse action (H.rEG) and delay the direct action (C.rEG) it is necessary to set positive values on parameter “thr1” and negative values on parameter “thr2”.

In this way, the area within which the two outputs are not activated at the same time is increased.

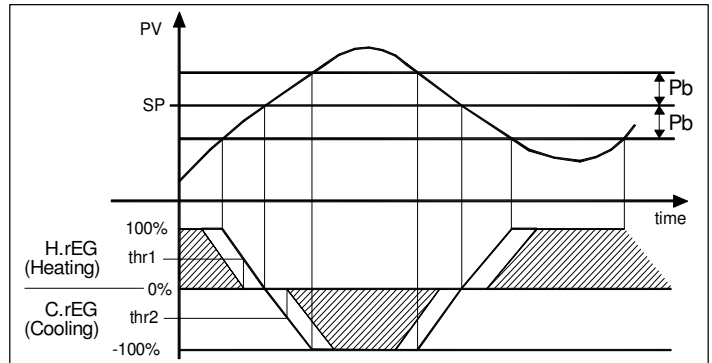

Vice versa if one wishes to extend the reverse action (H.rEG) and bring forward the direct action (C.rEG) it is necessary to set negative values on parameter “thr1” and positive values on parameter “thr2”.

In this way, the area within which the two outputs are activated at the same time is increased.

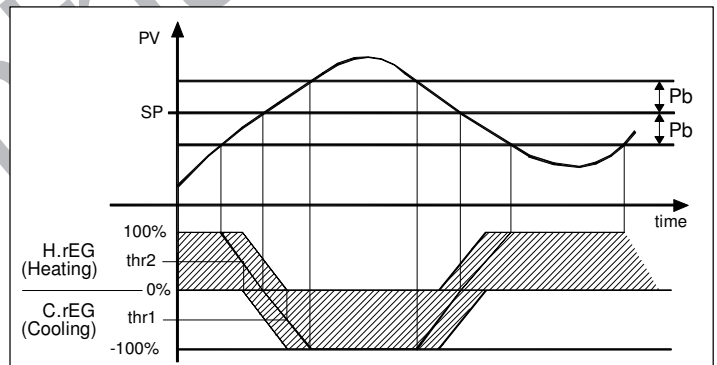

The split range function is deactivated by setting the respective parameters =0.

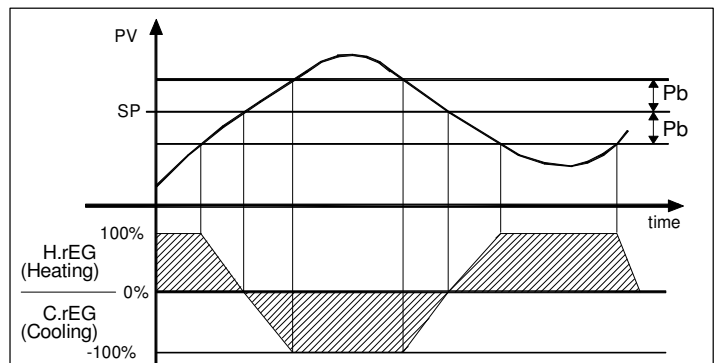

Note : In order to simplify the explanation of the example graphs a dual action control that is only proportional (and therefore with “dEr” and “Int” = OFF) with “Prat” = 1.0 and “rS” = 0.0 was considered.

[77] thr - Power threshold at which output H.rEG begins to operate.

Available: When two control action are programmed (H.rEG and c.rEG) and [55] cont = PID and [58].

Range: from -50 to 50 %

[78] thr - Power threshold at which output C.rEG begins to operate.

Available: When two control action are programmed (H.rEG and c.rEG) and [55] cont = PID and [58].

Range: from -50 to 50 %

[79] od – Delay at power up

Available: When at list one output is programmed as control output.

Range:

- oFF : Function not used
- from 0,01 to 99.59 hh.mm

Notes:

- This parameter defines the time during which (after a power up) the instrument remains in stand by mode before to start all other function (control, alarms, program, etc.)
- When a program with automatic start at power up and od function are programmed, the instrument performs od function before to start the program execution.
- When an auto-tune with automatic start at power up and od function are programmed, the od function will be aborted and auto-tune will start immediately.

[80] St.P - Maximum power output used during soft start

Available: When at list one output is programmed as control output and [55] cont = PID

Range: from -100 to 100 %

Notes:

- When St.P parameter have a **positive** value, the limit will be applied to the **heating** output(s) only.
- When St.P parameter have a **negative** value, the limit will be applied to the **cooling** output(s) only.
- When a program with automatic start at power up and soft start function are programmed, the instrument performs both functions at the same time. In other words, the program performs the first ramp, while the requested power is lower than the limit the instrument operates as usual, when the PID requires more then the limit the power output will be limited.
- The auto-tune function inhibits the soft start function

[81] SSt - Soft start time

Available: When at list one output is programmed as control output and annd [55] cont = PID

Range:

- oFF : Function not used
- from 0.01 to 7.59 hh.mm
- inF : soft start always active

[82] SS.tH – Threshold for soft start disabling

Available: When at list one output is programmed as control output and [55] cont = PID

Range: from -1999 to 9999 engineering units

Note:

- When the power limiter have a **positive** value (the limit is applied to the **heating** action) the soft start function will be aborted when the measured value is **greater** or equal to SS.tH parameter.

- When the power limiter have a **negative** value (the limit is applied to the **cooling** action) the soft start function will be aborted when the measured value is **lower** or equal to SS.tH parameter.

] SP Group - Set point parameters

The SP group will be available only when at least one output is programmed as control output (H.rEG or C.rEG).

[83] nSP – Number of used set points

Available: When at least one output is programmed as control output.

Range: from 1 to 4

Note: When you change the value of this parameter, the instrument operates as follows:

- [90] SPAt parameter will be forced to SP1.
- The instrument verifies that all used set point are within the limits programmed by [84] SPLL end [85] SPHL.

If an SP is out of this range, the instrument forces it to the limit more closed to it.

[84] SPLL - Minimum set point value

Available: When at least one output is programmed as control output.

Range: from -1999 to [85] SPHL engineering units

Notes:

- When you change the [83] SPLL value, the instrument checks all local set points ([86] SP1, [87] SP2, [88] SP3 and [89] SP4 parameters) and all set points of the program ([104] Pr.S1, [109] Pr.S2, [114] Pr.S3, [119] Pr.S4 parameters).

If an SP is out of this range, the instrument forces it to the maximum acceptable value

- A [84] SPLL change produces the following actions
 - when [91] SP.rt = SP the remote set point will be forced to be equal to the active set point
 - When [91] SP.rt = trim the remote set point will be forced to zero
 - When [91] SP.rt = PErC the remote set point will be forced to zero

[85] SPHL - Maximum set point value

Available: When at least one output is programmed as control output.

Range: from [84] SPLL to 9999 engineering units

Note: for other details see [84] SPLL parameter.

[86] SP 1 - Set Point 1

Available: When at least one output is programmed as control output.

Range: from [84] SPLL to [85] SPHL engineering units

[87] SP 2 - Set Point 2

Available: When at least one output is programmed as control output and [83] nSP > 1.

Range: from [84] SPLL to [85] SPHL engineering units

[88] SP 3 - Set Point 3

Available: When at least one output is programmed as control output and [83] nSP > 2.

Range: from [84] SPLL to [85] SPHL engineering units

[89] SP 4 - Set Point 4

Available: When at least one output is programmed as control output and [83] nSP = 4.

Range: from [84] SPLL to [85] SPHL engineering units

[90] SPAt - Selection of the active Set point

Available: When at least one output is programmed as control output.

Range: from "SP1" to [83] nSP.

Notes:

- A [90] SPAt change produces the following actions
 - when [91] SP.rt = SP - the remote set point will be forced to be equal to the active set point
 - When [91] SP.rt = trin - the remote set point will be forced to zero
 - When [91] SP.rt = PErc - the remote set point will be forced to zero
- SP2, SP3 and SP4 selection will be shown only the relative set point is enabled (see [83] nSP parameter).

[91] SP.rt – Remote set point type

These instrument will communicate with each other, using RS 485 serial interface without a PC. An instrument can be set as a Master while the other are (as usual) Slave units. The Master unit can send his operative set point to the slave units.

In this way, for example, it is possible to change simultaneously the set point of 20 instruments by changing the set point of the master unit (e.g. hot runner application).

SP.rt parameter defines how the slaves units will use the value coming from serial link.

The [136] tr.SP (Selection of the value to be retransmitted (Master)) parameter allows to define the value sent by master unit.

Available: When at least one output is e programmed as control output and the serial interface is present.

Range:

- rSP = The value coming from serial link is used as remote set point (RSP).
- trin = The value coming from serial link will be algebraically added to the local set point selected by SPAt and the sum becomes the

operative set point

PErc = The value coming from serial will be scaled on the input range and this value will be used as remote set point.

Note:

- A [80] SPrt change produces the following actions
 - when [91] SP.rt = rSP - the remote set point will be forced to be equal to the active set point
 - When [91] SP.rt = trin - the remote set point will be forced to zero
 - When [91] SP.rt = PErc - the remote set point will be forced to zero

Example:

A 6 zone reflow-oven for PCB .

The master unit sends its set point value to 5 other zones (slave controllers).

The Slave zones use it as a set point trim.

The first zone is the master zone and it uses a set point equal to 210 °C.

The second zone has a local set point equal to - 45 °C

The third zone has a local set point equal to -45 (°C)

The fourth zone has a local set point equal to -30

The fifth zone has a local set point equal to +40

The sixth zone has a local set point equal to +50

In this way, the thermal profile will be the following:

- master SP = 210 °C

- second zone SP = 210 -45 = 165 °C

- third zone SP = 210 -45 = 165 °C

- fourth zone SP = 210 - 30 = 180 °C

- fifth zone SP = 210 + 40 = 250 °C

- sixth zone SP = 210 + 50 = 260 °C

Changing the SP of the master unit, all the other slave units will immediately change their operative set point.

[92] SPLr – Local/remote set point selection

Available: When at list one output is programmed as control output.

Range:

Loc = local set point selected by [90] SPAt

rEn = Remote set point (coming from serial link)

[93] SP.u - Rate of rise for positive set point change (ramp up)

Available: When at list one output is e programmed as control output.

Range:

from 0.01 to 99.99 units per minute

inF = ramp disabled (step transfer)

[94] SP.d - Rate of rise for negative set point change (ramp down)

Available: When at list one output is e programmed as control output.

Range:

from 0.01 to 99.99 units per minute

inF = ramp disabled (step transfer)

General note about remote set point: when the

remote set point (RSP) with trim action is programmed, the local set point range becomes the following:
from [84] SP_{LL}+ RSP to [85] SP_{HL} - RSP

tin Group - Timer function parameters

Five timer types are available:

Delayed start with a delay time and a “end of cycle” time



- Setting tr.t2 = Inf the timer out remains in ON condition until a reset command is detected.

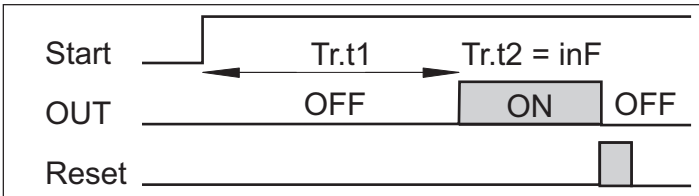

Delayed start at power up with a delay time and a “end of cycle” time

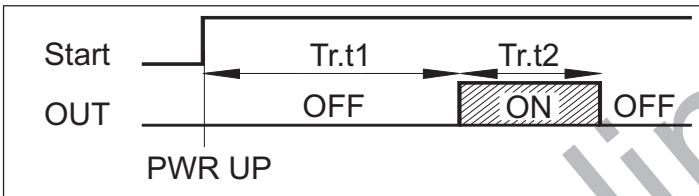

Feed-through

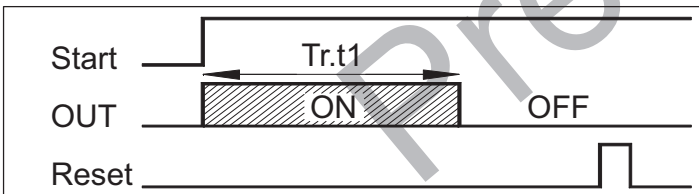

Asymmetrical oscillator with start in OFF

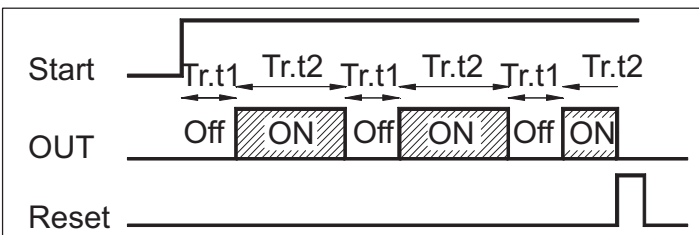

Asymmetrical oscillator with start in ON

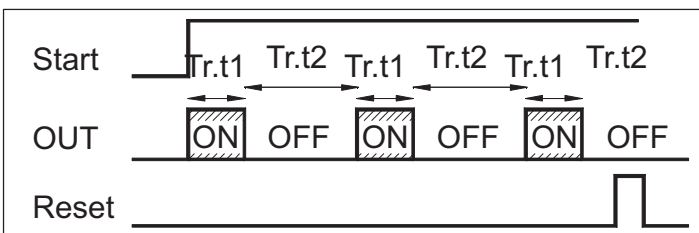

NOTES:

- The instrument can receive the start, hold and reset commands by U button, by logic inputs and/or by serial link
- An HOLD command can suspend the time count.

[95] tr.F = Independent timer function

Available: Always

Range:

- nonE = Timer not used
- i.d.A = Delayed start timer
- i.u.P.d = Delayed start at power up
- i.d.d = Feed-through timer
- i.P.L = Asymmetrical oscillator with start in OFF
- i.L.P = Asymmetrical oscillator with start in ON

[96] tr.u – Engineering unit of the time

Available: when [95] tr.F is different form nonE

Range:

- hh.nn = Hours and minutes
- nn.SS = Minutes and seconds
- SSS.d = Seconds and tenth of seconds

Note: when the timer is running, you can see the value of this parameter but you can NOT modify it.

[97] tr.t1 – Time 1

Available: when [95] tr.F is different form nonE

Range:

- when [96] tr.u = hh.nn from 00.01 to 99.59
- when [96] tr.u = nn.SS from 00.01 to 99.59
- when [96] tr.u = SSS.d from 000.1 to 995.9

[98] tr.t2 – Time 2

Available: when [95] tr.F is different form nonE

Range:

- when [96] tr.u = hh.nn from 00.01 to 99.59 + inf
- when [96] tr.u = nn.SS from 00.01 to 99.59 + inf
- when [96] tr.u = SSS.d from 000.1 to 995.9 + inf

Note: Setting [98] tr.t2 = inf, the second time can be stopped by a reset command only.

[99] tr.St – Timer status

Available: when [84] tr.F is different form nonE

Range:

- run = Timer Run
- HoLd = Timer Hold
- rES = Timer reset

Note: this parameter allows to manage timer execution by a parameter (without digital inputs or U button).

PrG Group - Programmer function parameter

These instruments are able to perform a set point profile compounded of 4 groups of 2 steps (8 step total).

The first step is a ramp (used to reach the desired set point), the second is a soak (on the desired set point).

When a RUN command is detected the instrument aligns the operative set point to the measured value and starts to execute the first ramp.

In addition, each soak is equipped with a wait band which suspends the time count when the measured value goes out of the defined band (guaranteed soak). Moreover, for each segment it is possible to define the status of two events. An event can drive an output and make an action during one or more specific program steps. Some additional parameters allow to define the time scale, the automatic RUN conditions and the instrument behaviour at the end of the program.

NOTES:

1) all steps can be modified during program execution.

2) During program execution the instrument memorize the segment currently in use and, by a 30 minutes interval, it memorize also the elapsed time of the soaks.

If a power down occurs during program execution, at the next power up the instrument is able to continue the program execution starting from the segment in progress at power down and, if the segment was a soak, it is also capable to restart from the soak time minus the elapsed time memorized.

In order to obtain this features, the "[120]dSPu - Status of the instrument at power u" parameter must be set to "AS.Pr".

If the "[120]dSPu" parameter is different from "AS.Pr" The memorization function will be inhibited.

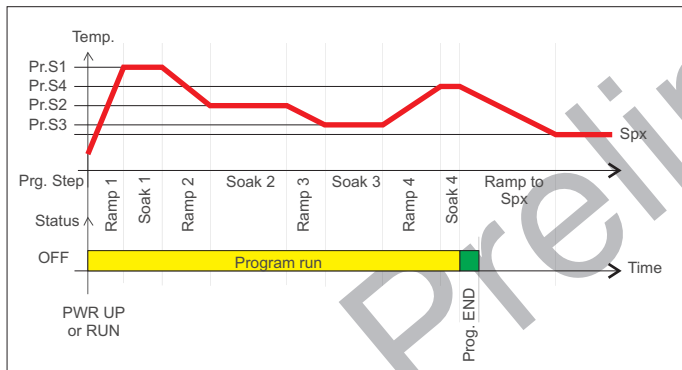

[100] Pr.F = Programmer action at power up

Available: Always

Range:

- nonE = Program not used
- S.uP.d = Start at power up with a first step in stand by
- S.uP.S = Start at power up
- u.diG = Start at RUN command detection only
- U.dG.d = Start at RUN command detection with a first step in stand by

[101] Pr.u – Engineering units of the soaks

Available: when [100] Pr.F is different from nonE

Range:

- hh.nn = Hours and minutes
- nn.SS = Minutes and seconds

Note: during program execution, this parameter can not be modified.

[102] Pr.E – Instrument behaviour at the End of the program execution

Available: when [100] Pr.F is different from nonE

Range:

- cnt = continue (the instrument will use the set point of the last soak until a reset command is detected)
- SPAt = go to the set point selected by [90] SPAt parameter
- St.bY = Go in stand by mode.

Note:

- Setting [102] Pr.E = cnt the instrument operates as follows: at program end, it will use the set point of the last soak. When a reset command is detected, it goes to the set point selected by [90] SPAt parameter. The transfer will be a step transfer or a ramp according to the [93] SP.u (Maximum rate of rise for positive set point change) and [94] SP.d (Maximum rate of rise for negative set point change).
- Setting [102] Pr.E = SPAt the instrument goes immediately to the set point selected by [79] SPAt parameter. The transfer will be a step transfer or a ramp according to the [93] SP.u (Maximum rate of rise for positive set point change) and [94] SP.d (Maximum rate of rise for negative set point change).

[103] Pr.Et – Time of the End program indication

Available: when [100] Pr.F is different from nonE

Range:

- oFF = Function not used
- from 00.01 to 99.59 minutes and seconds
- inF = indefinitely ON

Note:

- Setting [103] Pr.Et = inF the end program indication will go OFF only when a reset command or a new RUN command is detected.

[104] Pr.S1 - Set point of the first soak

Available: when [100] Pr.F is different from nonE or [100] Pr.F is different from S.uP.d.

Range: From [84] SPLl to [85] SPHL

[105] Pr.G1 – Gradient of the first ramp

Available: when [100] Pr.F is different from nonE or [100] Pr.F is different from S.uP.d.

Range:

- From 0.1 ÷ 999.9 eng. units per minute
- inF = Step transfer

[106] Pr.t1 – Time of the first soak

Available: when [100] Pr.F is different from nonE

Range: from 0.00 to 99.59 Time units.

[107] Pr.b1 – Wait band of the first soak**Available:** when [100] Pr.F is different from nonE or [100] Pr.F is different from S.uP.d.**Range:** from OFF to 9999 engineering units**Note:** the wait band suspends the time counting when the measured value goes out of the defined band (guaranteed soak).**[108] Pr.E1 – Events of the first group****Available:** when [100] Pr.F is different from nonE or [100] Pr.F is different from S.UP.d.**Range:** from 00.00 to 11.11 where

0 = event OFF

1 = event ON

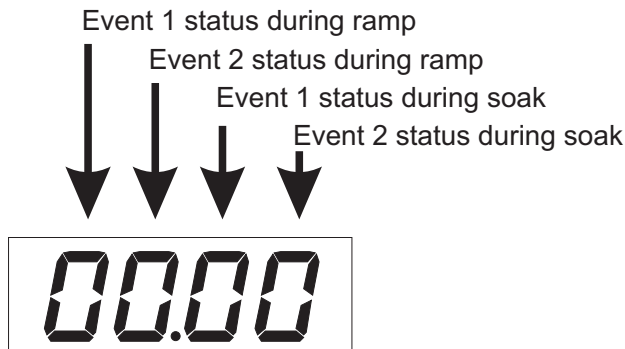

Display	Ramp		Soak	
	Event 1	Event 2	Event 1	Event 2
00.00 =	off	off	off	off
10.00 =	on	off	off	off
01.00 =	off	on	off	off
11.00 =	on	on	off	off
00.10 =	off	off	on	off
10.10 =	on	off	on	off
01.10 =	off	on	on	off
11.10 =	on	on	on	off
00.01 =	off	off	off	on
10.01 =	on	off	off	on
01.01 =	off	on	off	on
11.01 =	on	on	off	on
00.11 =	off	off	on	on
10.11 =	on	off	on	on
01.11 =	off	on	on	on
11.11 =	on	on	on	on

[109] Pr.S2 - Set point of the second soak**Available:** when [100] Pr.F is different from nonE**Range:**

- from [84] SPLL to [85] SPHL

- oFF = program end

Note: It is not necessary to configure all steps.

When you use for example 2 groups only, it is sufficient to set the set point of the third group equal to OFF. The instrument will mask all the following parameters of the programmer.

[110] Pr.G2 – Gradient of the second ramp**Available:** when [100] Pr.F is different from nonE and [109] Pr.S2 is different from oFF**Range:**

- From 0.1 ÷ 999.9 eng. units per minute

- inF = Step transfer

[111] Pr.t2 – Time of the second soak**Available:** when [100] Pr.F is different from nonE and [109] Pr.S2 is different from oFF**Range:** from 0.00 to 99.59 time units**[112] Pr.b2 – Wait band of the second soak****Available:** when [100] Pr.F is different from nonE and [109] Pr.S2 is different from oFF**Range:** from OFF to 9999 engineering units**Note:** for more details see [107]Pr.b1 parameter**[113] Pr.E2 – Events of the second group****Available:** when [100] Pr.F is different from nonE and [109] Pr.S2 is different from oFF**Range:** from 00.00 to 11.11 where

0 = event OFF

1 = event ON

Note: for more details see [108]Pr.E1 parameter.**[114] Pr.S3 - Set point of the third soak****Available:** when [100] Pr.F is different from nonE and [109] Pr.S2 is different from oFF**Range:**

- from [84] SPLL to [85] SPHL

- oFF = program end

Note: for more details see [109]Pr.S2 parameter.**[115] Pr.G3 – Gradient of the third ramp****Available:** when [100] Pr.F is different from nonE, [109] Pr.S2 is different from oFF and [114] Pr.S3 is different from OFF.**Range:**

- From 0.1 to 999.9 eng. units per minute

- inF = Step transfer

[116] Pr.t3 – Time of the third soak**Available:** when [100] Pr.F is different from nonE, [109] Pr.S2 is different from oFF and [114] Pr.S3 is different from OFF.**Range:** from 0.00 to 99.59 time units.**[117] Pr.b3 – Wait band of the third soak****Available:** when [100] Pr.F is different from nonE, [109] Pr.S2 is different from oFF and [114] Pr.S3 is different from OFF.**Range:** from OFF to 9999 engineering units**Note:** for more details see [107]Pr.b1 parameter**[107] Pr.E3 – Events of the third group****Available:** when [100] Pr.F is different from nonE, [109] Pr.S2 is different from oFF and [114] Pr.S3 is different

from OFF.

Range: from 00.00 to 11.11 where

0 = event OFF

1 = event ON

Note: for more details see [108]Pr.E1 parameter.

[119] Pr.S4 - Set point of the fourth soak

Available: when [100] Pr.F is different from nonE, [109] Pr.S2 is different from oFF and [114] Pr.S3 is different from OFF.

Range:

- from [84] SPLL to [85] SPHL

- oFF = program end

Note: for more details see [109]Pr.S2 parameter.

[120] Pr.G4 – Gradient of the fourth ramp

Available: when [100] Pr.F is different from nonE, [109] Pr.S2 is different from oFF, [114] Pr.S3 is different from OFF and [119] Pr.S4 is different from OFF

Range:

- From 0.1 ÷ 999.9 eng. units per minute

- inF = Step transfer

[121] Pr.t4 – Time of the fourth soak

Available: when [100] Pr.F is different from nonE, [109] Pr.S2 is different from oFF, [114] Pr.S3 is different from OFF and [119] Pr.S4 is different from OFF

Range: from 0.00 to 99.59 time units.

[122] Pr.b4 – Wait band of the fourth soak

Available: when [100] Pr.F is different from nonE, [109] Pr.S2 is different from oFF, [114] Pr.S3 is different from OFF and [119] Pr.S4 is different from OFF

Range: from OFF to 9999 engineering units

Note: for more details see [107]Pr.b1 parameter

[123] Pr.E4 – Event of the fourth segment

Available: when [100] Pr.F is different from nonE, [109] Pr.S2 is different from oFF, [114] Pr.S3 is different from OFF and [119] Pr.S4 is different from OFF

Range: from 00.00 to 11.11 where

0 = event OFF

1 = event ON

Note: for more details see [108]Pr.E1 parameter.

[124] Pr.St – Program status

Available: when [100] Pr.F is different from nonE

Range:

- run = Program Run

- HoLd = Program Hold

- rES = Program reset

Note: this parameter allows to manage program execution by a parameter.

“] PAN” group - Operator HMI

[125] PAS2 – Level 2 password: Limited access level

Available: Always

Range:

- oFF = Level 2 not protected by password (as level 1 = Operator level).

- from 1 to 999.

[126] PAS3 – Level 3 password : configuration level

Available: Always

Range: from 3 to 999.

Note: Setting [125] PAS2 equal to [126] PAS3, the level 2 will be masked.

[127] uSrb - U button function during RUN TIME

Available: ever

Range:

nonE = No function

tunE = Auto-tune/self-tune enabling

A single press (longer than 1 second) starts the auto-tune .

oPLo = Manual mode.

The first pressure puts the instrument in manual mode (OPLo) while a second one puts the instrument in Auto mode.

AAc = Alarm reset

ASi = Alarm acknowledge

chSP = Sequential set point selection (see note below).

St.by = Stand by mode

The first press puts the instrument in stand by mode while a second one puts the instrument in Auto mode.

Str.t = Timer run/hold/reset

(see note below).

P.run = Program run

(see note below).

P.rES = Program reset.

(see note below).

P.r.H.r = Program run/hold/reset

(see note below).

NOTES:

- When “Sequential set point selection” is used, every press of the U button (longer than 1 second) increase the value of SPAT (active set point) of one step. The selection is cyclic -> SP1 -> SP2 -> SP3 -> SP4

Note: when a new set point is selected using the U key, the display will show for 2 seconds the acronym of the new set point (e.g. SP2).

- When “Sequential set point selection” is used, the number of set points selecteble is limited by [69] nSP.

- When “Timer run/hold/reset” is selected, a short press starts/stops(hold) timer count while a long press (longer than 10 second) resets the timer.

- When “Program run” is selected, the first press starts

the program execution but a second press **restarts** the program execution from the beginning.

- When "Program reset" is selected, a short press allows it to reset the program execution.
- When "Program run/hold/reset" is selected, a short press starts/stop(Hold) program execution while a long press (longer than 10 second) resets the program.

[128] diSP – Display management

Available: Always

Range:

- nonE = Standard display
- Pou = Power output
- SPF = Final set point
- Spo = Operative set point
- AL1 = Alarm 1 threshold
- AL2 = Alarm 2 threshold
- AL3 = Alarm 3 threshold
- Pr.tu = - During a soak, the instrument will show the elapsed time of the soak
 - During a ramp the display will show the operative set point.At the end of the program execution, the instrument will show "P.End" messages alternately with the measured value.
 - When no program is running, the instrument will show the standard display.
- Pr.td = - During a soak, the instrument will show the remaining time of the soak (count down).
 - During a ramp the display will show the operative set point.At the end of the program execution, the instrument will show "P.End" messages alternately with the measured value.
 - When no program is running, the instrument will show the standard display.
- P.t.tu = When the programmer is running, the display will show the total elapsed time. At the end of the program execution, the instrument will show "t.End" messages alternately with the measured value.
- P.t.td = When the programmer is running, the display will show the total remaining time (count down). At the end of the program execution, the instrument will show "P.End" messages alternately with the measured value.
- ti.uP = When the timer is running, the display will show the timer counting up. At the end of the counting, the instrument will show "t.End" messages alternately with the measured value.
- ti.du = When the timer is running, the display will show the timer counting down. At the end of the counting, the instrument will show "t.End" messages alternately with the measured value.

[129] AdE - Bar-graph deviation

Available: Always

Range:

- oFF Bar-graph not used
- from 1 to 9999 engineering units.

[130] FiLd - Filter on the displayed value

Available: Always

Range:

- oFF Filter disabled
- from 0.1 to 20.0 engineering units.

Note:

This is a "window filter" related to the set point; it is applied to the displayed value only and it have no effect on the other functions of the instrument (control, alarms, etc.).

[131]dSPu - Status of the instrument at power up

Available: Always

Range:

- AS.Pr = Starts in the same way it was prior to the power down.
- Auto = Starts in Auto mode
- oP.0 = Starts in manual mode with a power output equal to zero.
- St.bY = Starts in stand-by mode

[132] oPr.E - Operative modes enabling

Available: Always

Range:

- ALL = All modes will be selectable by the next parameter.
- Au.oP = Auto and manual (OPLO) mode only will be selectable by the next parameter.
- Au.Sb = Auto and Stand-by modes only will be selectable by the next parameter.

NOTES:

- 1) when you change the value of [121] oPr.E, the instrument forces [122] oPEr parameter equal to Auto.
- 2) **During program execution the instrument memorize the segment currently in use and, by a 30 minutes interval, it memorize also the elapsed time of the soaks.**
If a power down occurs during program execution, at the next power up the instrument is able to continue the program execution starting from the segment in progress at power down and, if the segment was a soak, it is also capable to restart from the soak time minus the elapsed time memorized.
In order to obtain this features, the "[131]dSPu - Status of the instrument at power u" parameter must be set to "AS.Pr".
If the "[131]dSPu" parameter is different from "AS.Pr" The memorization function will be hinhibit.

[133] oPEr – Operative mode selection

Available: Always

Range:

When [132] oPr.E = ALL

Auto = Auto mode
 oPLo = Manual mode
 St.bY = Stand by mode

When [132] oPr.E = Au.oP

Auto = Auto mode
 oPLo = Manual mode

When [132] oPr.E = Au.Sb

Auto = Auto mode
 St.bY = Stand by mode

] Ser group - Serial link parameter**[134] Add - Instrument address****Available:** Always**Range:**

- oFF = Serial interface not used
 - from 1 to 254

[135] bAud - Baud rate**Available:** when [134] Add different from oFF**Range:**

1200 = 1200 baud
 2400 = 2400 baud
 9600 = 9600 baud
 19.2 = 19200 baud
 38.4 = 38400 baud

[136] trSP – Selection of the value to be retransmitted (Master)**Available:** when [134] Add different from oFF**Range:**

nonE = Retransmission not used (the instrument is a slave)
 rSP = The instrument become a Master and it retransmits the operative set point.
 PErc = The instrument become a Master and it retransmits the power output.

Note: for more details see [91] SP.rt (Remote set point type) parameter.**] COn Group - Consumption parameters****[137] Co.tY – Measurement type****Available:** Always**Range:**

oFF = Not used
 1 = Instantaneous power (kW)
 h = Power consumption (kW/h)
 2 = Energy used during program execution.
 This measure starts from zero when a

program runs end stops at the end of the program. A new program execution will reset the value.

3 = Total worked days with threshold. It is the number of hours that the instrument is turned ON divided for 24.

4 = Total worked hours with threshold. It is the number of hours that the instrument is turned ON.

Note:

Items 3 and 4 are an internal counter for machine service inspection intervals. It works every time the instrument is turned ON.

When the count reaches the programmed threshold, the display shows alternately the standard display and the message “r. iSP” (requested Inspection). The count reset can be done only by changing the threshold value.

[138] UoLt – nominal Voltage of the load**Available:** when [137] Co.tY = ist or [137] Co.tY = h or [137] Co.tY = S.S**Range:** from 1 to 9999 (V)**[139] cur – Nominal current of the load****Available:** when [137] Co.tY = ist or [137] Co.tY = h or [137] Co.tY = S.S**Range:** from 1 to 999 (A)**[140] h.Job – Threshold of the working period****Available:** when [137] Co.tY = tot.d or [137] Co.tY = tot.H**Range:**

- oFF = threshold not used
 - from 1 to 999 days or
 - from 1 to 999 hours.

1 CAL group - user calibration group

This function allows to calibrate the complete measuring chain and to compensate the errors due to:

- Sensor location
- Sensor class (sensor errors)
- Instrument accuracy

[141] AL.P – Adjust Low Point**Available:** Always**Range:** from -1999 to (AH.P - 10) engineering units**Note:** the minimum difference between AL.P and AH.P is equal to 10 Engineering Units.**[142] ALo – Adjust Low Offset****Available:** Always**Range:** from -300 to 300 Engineering Units**[143] AH.P – Adjust High Point****Available:** Always**Range:** from (AL.P + 10) to 9999 engineering units

Note: the minimum difference between AL.P and AH.P is equal to 10 Engineering Units

[144] AL.o – Adjust Low Offset

Available: Always

Range: from -300 to 300 Engineering Units

Example: Environmental chamber with an operative range from 10 to + 100 °C.

- 1) Insert in the chamber a reference sensor connected with a reference instrument (usually a calibrator).
- 2) Start the control of the instrument, and set a set point equal to the minimum value of the operative range (e.g. 10 °C)
When the temperature in the chamber is steady, take note of the temperature measured by the reference system (e.g. 9 °C).
- 3) Set [141] AL.P = 10 (low working point) and [142] ALo = -1 (it is the difference between the reading of the instrument and the reading of the reference system). Note that after this set the measured value of the instrument is equal to the measured value of the reference system.
- 4) Set a set point equal to the maximum value of the operative range (e.g. 100 °C). When the temperature in the chamber is steady, take note of the temperature measured by the reference system (e.g. 98 °C).
- 5) Set [143] AH.P = 100 (low working point) and [144] ALo = +2 (it is the difference between the reading of the instrument and the reading of the reference system). Note that after this set the measured value of the instrument is equal to the measured value of the reference system.

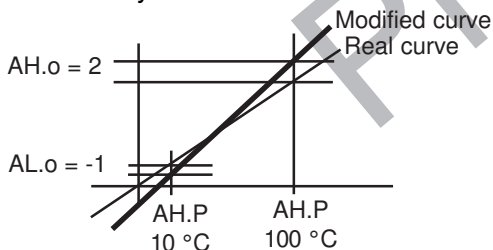

The most important step of the configuration procedure is completed.

In order to exit from configuration parameter procedure, proceed as follows:

- Push U button.
- Push U button for more than 10 seconds
- The instrument will come back to the “standard display”.

5. PARAMETERS PROMOTION

Another important step of the instrument configuration is due to the possibility to create a custom HMI (interface) in order to make the instrument easy to use for the operator and comfortable for the

assistance.

By a special procedure, named promotion, the OEM can create two parameter subsets.

The first one is the “limited access” level.

This subset is protected by the password programmed by [125] PAS2 parameter.

The last subset is the “Operator” set (Level1).

This level is NOT password protected.

Notes:

- The “limited access” parameter are collected in a list.
- The sequence of the “limited access” parameters is programmable and can be made according to your needs
- The parameter sequence of the operator level is the same programmed for “limited access” level but only specified parameters can be displayed and modified. This set must be create according to your requirements

5.1 PARAMETERS PROMOTION PROCEDURE

The limited access parameter set is a list, so that, before to start promotion procedure, we suggest to operate as follows:

- 1) Prepare the exact parameter list you want to make accessible for limited access.
- 2) Number the desired parameters in the same sequence you want to have in the limited access.
- 3) Define which of the selected parameter will be available in Operator level also.

Example:

I would like to obtain the following limited access list:

- OPER - Operative mode selection
- SP1 - first sset point
- SP2 - Second set point
- SPAt - Set point selection
- AL1 - Alarm 1 threshold
- AL2 - Alarm 2 threshold
- Pb - Proportional band
- Int - Integral time
- dEr - Derivative time
- Aut.r - Manual start of the auto-tune

But I want that the operator to be able to change: the operative mode, the SP1 value and the AL1 value.

In this case the promotion will be the following:

Param.	Promotion	Limited Access	Operator
- OPER -	o 1	OPER	OPER
- SP1 -	o 2	SP1	SP1
- SP2 -	A 3	SP2	
- SPAt -	A 4	SPAt	
- AL1 -	o 5	AL1	AL1
- AL2 -	A 6	AL2	
- Pb -	A 7	Pb	
- Int -	A 8	Int	
- dEr -	A 9	dEr	
- Aut.r -	A 10	Aut.r	

Now, proceed as follows:

- 1) Push the P button for more than 3 seconds.
- 2) The display will show alternately “PASS” and “0”.

- 3) By ▲ and ▼ button set a password equal to - 81.
- 4) Push P button.
The instrument will show the acronym of the first configuration parameter group "inP".
- 5) By U button select the group of the first parameter of your list.
- 6) By P button select the first parameter of your list.
- 7) The instrument will show alternately the acronym of the parameter and his current promotion level.
The promotion level is defined by a letter followed by a number.
The letter can be:
 - "c": it shows that this parameter is NOT promoted and it is present only in configuration.
In this case the number is forced to zero.
 - "A": it shows that this parameter has been promoted to the limited access level.
The number will show the position in the limited access list.
 - "o": it shows that the parameter has been promoted to the Operator level.
The number will show the position in the limited access list.
- 8) By ▲ and ▼ button assign to this parameter the desired position.
Note: setting a value different from 0 the letter "c" will change automatically to "A" and the parameter is automatically promoted to the limited access level.
- 9) In order to modify the level from limited access to operator and vice versa, push U button and, maintaining the pressure, push Up button.
The letter will change from "A" to "o" and vice versa.
- 10) Select the second parameter that you want to add to the "limited access" level and repeat step 6, 7 and 8.
- 11) Repeat step 6, 7, 8 until the list has been completed.
- 12) When you need to exit from promotion procedure, push U button and maintain the pressure for more than 10 seconds.

The instrument will show the "standard display".

NOTE: when you set the some number to two parameter, the instrument will use only the last programmed parameter.

Example: in the previous example, I have set for SP2 a promotion value equal to A3.

If now I set for SP3 a promotion value equal to o3, the Limited Access list and the operator list becomes.

Param.	Promotion	Limited Access	Operator
- OPEr -	o 1	OPEr	OPEr
- SP1 -	o 2	SP1	SP1
- SP3 -	o 3	SP3	SP3
- SPAt -	A 4	SPAt	
- AL1 -	o 5	AL1	AL1
.....			

6. OPERATIVE MODES

As we said at paragraph 4.1, when the instrument is powered, it starts immediately to work according to the memorized parameter value.

In other words, the instrument has one status only, the "run time" status.

During "run time" we can force the instrument to operate in three different modes: Automatic mode, Manual mode or Stand by mode.

- In Automatic mode the instrument drives automatically the control output according to the parameter value set and the setpoint/measured value.

- In Manual mode the instrument shows the measured value and allows you to set manually the control output power.

No Automatic action will be made.

- In stand by mode the instrument operates as an indicator. It will show the measured value and forces the control outputs to zero.

As we have seen, it is always possible to modify the value assigned to a parameter independently from the operative modes selected.

6.1 HOW TO ENTER INTO THE "OPERATOR LEVEL"

The instrument is showing the "standard display".

- 1) Press the P button
- 2) The instrument will show alternately the acronym of the first parameter promoted to this level and its value.
- 3) By ▲ and ▼ button assign to this parameter the desired value.
- 4) Press the P button in order to memorize the new value and go to the next parameter.
- 5) When you want to come back to the "standard display" push the U button for more than 5 seconds.

NOTE: the parameter modification of the Operator level is subject to a time out. If no button is pressed for more than 10 seconds, the instrument goes back to the "standard display" and the new value of the last selected parameter will be lost.

6.2 HOW TO ENTER INTO THE "LIMITED ACCESS LEVEL"

The instrument is showing the "standard display".

- 1) Press the P button for more than 5 seconds
- 2) The display will show alternately "PASS" and "0".
- 3) By ▲ and ▼ button set the value assigned to [114] PAS2 (Level 2 password).

NOTES:

- a) The factory default password for configuration parameters is equal to 20.
- b) All parameter modification are protected by a time out. If no button is pressed for more than 10 second the instrument comes automatically back to the Standard display, the new value of the last selected parameter is lost and the parameter modification procedure is closed.

When you desire to remove the time out (e.g. for the first configuration of an instrument) you can use a password equal to 1000 plus the programmed password (e.g. 1000 + 20 [default] = 1020). It is always possible to manually End the parameter configuration procedure (see below).

- c) During parameter modification the instrument continues to perform the control.
In certain conditions (e.g. when a parameter change can produce a heavy bump to the process) it is advisable to temporarily stop the controller from controlling during the programming procedure (its control output will be Off). A password equal to 2000 + the programmed value (e.g. 2000 + 20 = 2020) will switch the control out off during configuration. The control will restart automatically when the parameter modification procedure will be manually ended.
- 4) Push P button.
- 5) The instrument will show alternately the acronym of the first parameter promoted to this level and its value.
- 6) By ▲ and ▼ button assign to this parameter the desired value.
- 7) Press the P button in order to memorize the new value and go to the next parameter.
- 8) When you want to come back to the “standard display” push the U button for more than 5 seconds.

6.3 HOW TO SEE BUT NOT MODIFY THE “LIMITED ACCESS PARAMETERS”

Sometime it is necessary to give to the operator the possibility to see the value assigned to the parameter promoted in the Limited Access level but it is important that all changes are made by authorized personnel only. In this cases, proceed as follows:

- 1) Press the P button for more than 5 seconds
- 2) The display will show alternately “PASS” and “0”.
- 3) By ▲ and ▼ button set the value -181.
- 4) Push P button.
- 5) The instrument will show alternately the acronym of the first parameter promoted to the level 2 and its value.
- 6) Using P button it is possible to see the value assigned to all parameter present in level 2 but it will not be possible to modify it.
- 7) It is possible to come back to the “standard display” by pushing the U button for more than 3 seconds or by pushing no pushbutton for more than 10 seconds.

6.4 AUTOMATIC MODE

6.4.1 Keyboard function when the instrument is in Auto mode

- U It will perform the action programmed by [116] uSrb (U button function during RUN TIME) parameter.

- P It allows entry into parameter modification procedures.
- ▲ It allows you to start the “Direct set point modification” function (see below).
- ▼ it allows you to display the “additional informations” (see below).

6.4.2 Direct set point modification

This function allows to modify rapidly the set point value selected by [79] SPAt (selection of the active Set point) or to the set point of the segment group (of the programmer) currently in progress.

The instrument is showing the “standard display”.

- 1) Push ▼ button.
The display will show alternately the acronym of the selected set point (e.g. SP2) and its value
NOTE: when the programmer is running, the instrument will show the set point of the group currently in use (e.g. if the instrument is performing the soak 3 the instrument will show [104] Pr.S3).
- 2) By ▲ and ▼ buttons, assign to this parameter the desired value
- 3) Do not push any button for more than 5 second or push the P button.
In both cases the instrument memorize the new value and come back to the “standard display”.

NOTE: If the selected set point has not been promoted to the Operator level, the instrument allows you to see the value but not to modify it.

6.4.3 Additional informations

This instrument is able to show you some additional informations that can help you to manage your system. The additional information is related to how the instrument is programmed, hence in many cases, only part of this information is available.

- 1) When the instrument is showing the “standard display” push ▲ button.
The display will show “H” or “c” followed by a number. This value is the current power output applied to the process. The “H” show you that the action is a Heating action while the “c” show you that the action is a Cooling action.
- 2) Push ▲ button again. When the programmer is running the instrument will show the segment currently performed and the Event status as shown below:

 where the first character can be “r” for a ramp or “S” for a soak, the next digit show the number of the segment (e.g. S3 means Soak number 3) and the two less significant digits (LSD) show you the status of the two event (the LSD is the Event 2).

- 3) Push ▲ button again. When the programmer is running the instrument will show the theoretical remaining time to the end of the program preceded by a P letter:

P84.3

- 4) Push ▲ button again. When the wattmeter function is running the instrument will show "U" followed by the measured energy.
 Note: The energy calculation will be in accordance with the [123] Co.tY parameter setting.
- 5) Push ▲ button again. When the "Worked time count" is running the instrument will show "d" for days or "h" for hours followed by the measured time.
- 6) Push ▲ button again. The instrument will come back to the "standard display".

NOTE: The additional information visualization is subject to a time out. If no button is pressed for more than 10 second the instrument comes automatically back to the Standard display,

6.4.4 The programmer function

In paragraph 4 (page 18) we have described all parameters related with the programmer and their action during program execution.

In this paragraph we will give you some additional informations and some application examples.

Notes:

- The decimal point of the LSD is used to show the programmer status independently from the displayed value selected by [114] diSP (Display management).

8888.

Decimal point of the LSD.

The relation between the programmer status and the LED are the following:

- Program in RUN - the LED is ON.
- Program in Hold - The LED is flashing fast
- Program in wait - The LED is flashing slow
- Program in end or reset - The LED is OFF

Application Example 1: Spray Paint Drying Booth.

When the operator is in the booth and painting the car, the internal temperature must be 20 °C and the air, used for booth ventilation, comes from outside.

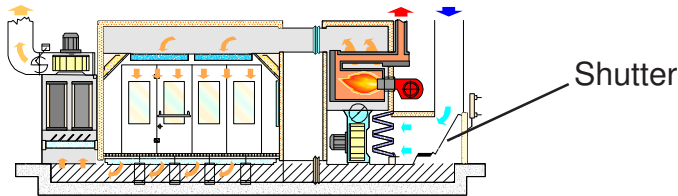

During the passivation and drying phases, the operator is out of the booth and the system closes the shutter of the air and recycles the internal air in order to reduce the power consumption.

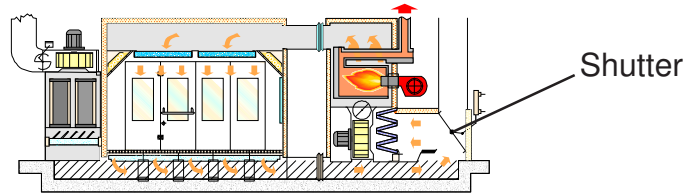

When the drying time is finished, before the operator is allowed to enter into the booth, you must be sure that:

- 1) the air in the booth has been refreshed
- 2) the temperature is lower than a limit.

So that you need a profile like below:

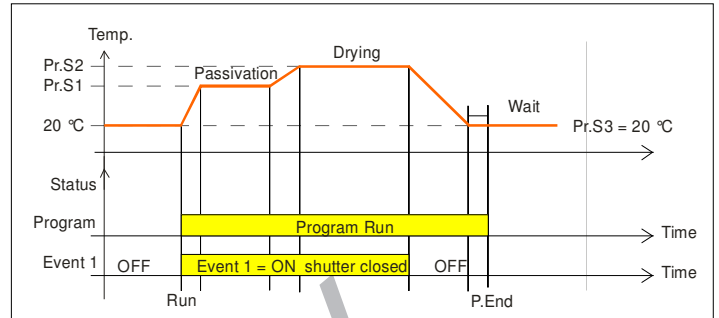

Out 1 = H.rEG (heating output)

Out 2 = P.Et1 (program event 1)

Out 3 = P.run (program running)

Pr.E1 and Pr.E2 = 10.10 (event 1 goes ON during ramp 1, soak 1, ramp 2 and soak 2)

When the program is running the door is locked

Application Example 2: edgb anding machine with glue tank (for wood).

At the working temperature the hot melt rapidly oxidizes and runs down from the "dispenser".

For this reason, when the machine does not work for a certain time, it is suitable to move the temperature of the dispenser to a lower value to idle.

In this cases the configuration is the following:

Out 1 = h.reg (heating output)

Out 2 = AL (alarm used to enable the dragger)

diF.1 = P.run (dig. input 1 used for Program run/restart)

Pr.F = S.uP.S (start at power up)

Pr.E = cnt (Instrument behaviour at the end of the program execution = continue).

Connect a proximity switch to Dig. In 1 for panel detection.

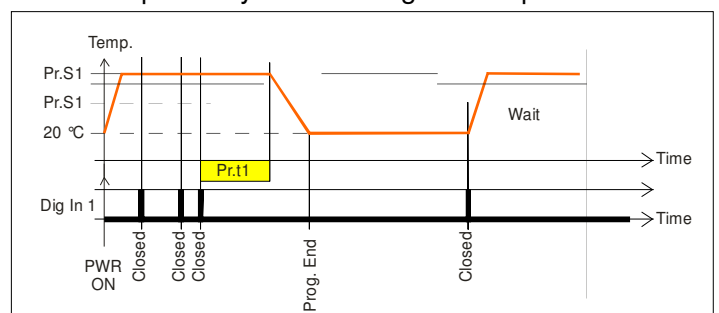

When a new panel is detected before the end of the first soak time, the program restarts and the set point remain equal to Pr.S1.

If no panel is detected, the instrument goes to Pr.S2 (idle temp) and remain there until a new panel arrives.

6.5 MANUAL MODE

This operative mode allows you to deactivate automatic control and manually program the percentage power output to the process.

When manual mode is selected the display will show alternately the measured value and the message "oPLo".

When manual control is selected, the instrument will start to operate with the same power output as the last one supplied by automatic mode and can be modified

using the ▲ and ▼ buttons.

In case of ON/OFF control, 0% corresponds to the deactivated output while any value different from 0 corresponds to the activated output.

As in the case of visualization, the programmable values range from H100 (100% output power with reverse action) to C100 (100% output power with direct action).

Note:

- During manual mode, the absolute alarms are operative while the relative alarms are disabled.
- If you set manual modes during program execution, the program will be aborted.
- If you set manual modes during self-tune execution, the self-tune function will be aborted.
- During manual mode, all functions not related with the control (wattmeter, independent timer, "worked time", etc) continue to operate normally.

6.6 STAND-BY MODE

This operative mode also deactivates the automatic control but forces the control output to zero.

In this mode the instrument operates as an indicator. When stand by mode is selected the display will show alternately the measured value and the message "St.bY".

Note:

- During stand by mode, the relative alarms are disabled while the absolute alarms are operative or not according to the ALxo (Alarm x enabling during Stand-by mode) parameter setting.
- If you set stand by mode during program execution, the program will be aborted.
- If you set stand by mode during self-tune execution, the self-tune function will be aborted.
- During stand by mode, all functions not related with the control (wattmeter, independent timer, "worked time", etc) continue to operate normally.
- When the instrument is swapped from stand by to auto modes, the instrument will start automatically the alarm masking, and the soft start functions.

7. ERROR MESSAGES

7.1 OUT OF RANGE SIGNALS

The display shows the OVER-RANGE and UNDER-RANGE conditions with the following indications:

Over-range

Under-range

The sensor break will be signalled as an out of range

NOTE: When an over-range or an under-range is detected, the alarms operate as in presence of the maximum or the minimum measurable value respectively.

To check the out of span Error condition, proceed as follows:

- 1) Check the input signal source and the connecting line.
- 2) Make sure that the input signal is in accordance with the instrument configuration. Otherwise, modify the input configuration (see section 4).
- 3) If no error is detected, send the instrument to your supplier to be checked.

7.2 LIST OF POSSIBLE ERRORS

ErAT - Fast Auto-tune can't start. The measure value is too close to the set point.

Push the P button in order to delete the error message.

NoAt - Auto-tune not finished within 12 hours.

ErEP- Possible problem of the instrument memory.

The messages disappears automatically.

When the error continues, send the instrument to your supplier.

8. - GENERAL NOTES

8.1 - PROPER USE

Every possible use not described in this manual must be considered as an improper use.

This instrument is in compliance with EN 61010-1 "Safety requirements for electrical equipment for measurement, control and laboratory use"; for this reason it could not be used as a safety equipment.

Whenever a failure or a malfunction of the control device may cause dangerous situations for persons, things or animals, please remember that the plant has to be equipped with additional safety devices.

Tecnologic S.p.A. and its legal representatives do not assume any responsibility for any damage to people, things or animals deriving from violation, wrong or improper use or in any case not in compliance with the instrument's features.

8.2 - GUARANTEE AND REPAIRS

This product is under warranty against manufacturing defects or faulty materials that are found within 12 months from delivery date.

The guarantee is limited to repairs or to the replacement of the instrument.

The tampering of the instrument or an improper use of the product will bring about the immediate withdrawal of the warranty's effects.

In the event of a faulty instrument, either within the period of warranty, or further to its expiry, please contact our sales department to obtain authorisation for sending the instrument to our company.

The faulty product must be shipped to Tecnologic with a detailed description of the faults found, without any fees or charge for Tecnologic, except in the event of alternative agreements.

8.3 MAINTENANCE

This instrument does not require periodical recalibration and it has no consumable parts so that no particular maintenance is required.

Some times, a cleaning action is suggestable.

- 1) SWITCH THE EQUIPMENT OFF (power supply, relay out, etc.).
- 2) Take the instrument out of its case.
- 3) Using a vacuum cleaner or a compressed air jet (max. 3 kg/cm²) remove all deposits of dust and dirt which may be present on the louvers and on the internal circuits being careful not to damage the electronic components.
- 4) To clean external plastic or rubber parts use only a cloth moistened with:
 - Ethyl Alcohol (pure or denatured) [C₂H₅OH] or
 - Isopropyl Alcohol (pure or denatured) [(CH₃)₂CHOH] or
 - Water (H₂O).

- 5) Make sure that there are no loose terminals.
- 6) Before putting the instrument back in its case, make sure that it is perfectly dry.
- 7) Put the instrument back and turn it ON.

8.4 ACCESSORIES

The instrument has a lateral socket into which a special tool can be inserted. This tool, named A03, allows:

- To memorize a complete instrument configuration and to use it for other instruments.
- To transfer a complete instrument configuration to a PC or from a PC to an instrument
- To transfer from a PC to an instrument a complete instrument configuration
- To transfer a configuration from an A03 to another one.
- To test serial interface of the instruments and to help the OEM during machine start up.

Appendix A

InP group

n°	Parameter	Description	Dec.	Range	Def.	Vis. Promo.
1	HcFG	Parameter available by serial link. It shows the current hardware.	0	TC/RTD TC/PTC Current Voltage	According to the Hardw.	Not vis
2	SEnS	Sensor selection (according to the hardware) TC, Pt100 input TC, PTC, NTC input I input V input	0	J, crAL, S , r, t, Ir.J, Ir.cA, Pt1, 0.50 (mV), 0.60 (mV) 12.60 (mV) J, crAL, S , r, t, Ir.J, Ir.cA, Ptc, ntc, 0.50 (mV), 0.60 (mV), 12.60 (mV) 0.20 (mA), 4.20 (mA) 0.5(V), 1.5(V), 0.10(V), 2.10(V), 0.1 (V)	J Ptc 4.20 0.10	A-4
3	dP	Decimal figures	0	From 0 to 3	0	A-5
4	SSc	Initial scale readout	dP	From -1999 to FSC (E.U.)	-1999	A-6
5	FSc	Final scale readout	dP	From SSc to 9999 (E.U.)	9999	A-7
6	unit	Engineering unit	0	°c or °F	0 = °c	A-8
7	FiL	Digital filter on the measured value	1	From 0(oFF) to 20.0 (s)	1.0	C-0
8	inE	Selection of the Sensor Out of Range type that will enable the safety output value	0	or = Over-range ur = Under-range our = Over and Under	our	C-0
9	oPE	Safety output value	0	from -100 to 100 (%)	0	C-0
10	diF1	Digital input 1 function	0	oFF = No function 1 = Alarm Reset 2 = Alarm acknowledge (ACK) 3 = Hold of the measured value 4 = Stand by mode 5 = HEAt with SP1 and Cool with "SP2" 6 = Timer run/hold/reset [transition] 7 = Timer run [transition] 8 = Timer reset [transition] 9 = Timer run/hold [Status] 10 = Program run 11 = Program reset 12 = Program hold 13 = Program run/hold 14 = Program run/reset 15 = Instrument in Manual mode 16 = Sequential set point selection 17 = SP1 / SP2 selection 18 = Set point Binary selection 19 = Digital inputs in parallel to the UP and Down keys	nonE	A-13
11	diF2	Digital input 2 function	0	oFF = No function 1 = Alarm Reset 2 = Alarm acknowledge (ACK) 3 = Hold of the measured value 4 = Stand by mode 5 = HEAt with SP1 and Cool with "SP2" 6 = Timer run/hold/reset [transition] 7 = Timer run [transition] 8 = Timer reset [transition] 9 = Timer run/hold [Status] 10 = Program run 11 = Program reset 12 = Program hold 13 = Program run/hold	nonE	A-14

n°	Parameter	Description	Dec.	Range	Def.	Vis. Promo.
				14 = Program run/reset 15 = Instrument in Manual mode 16 = Sequential set point selection 17 = SP1 / SP2 selection 18 = Set point Binary selection 19 = Digital inputs in parallel to the UP and Down keys		

Out group

n°	Parameter	Description	Dec.	Range	Def.	Vis. Promo.
12	o1F	Out 1 function	0	NonE = Output not used, H.rEG = Heating output c.rEG = Cooling output AL = Alarm output t.out = Timer output t.HoF = Timer out -OFF in hold P.End = Program end indicator P.HLd = Program hold indicator P. uit = Program wait indicator P.run = Program run indicator P.Et1 = Program Event 1 P.Et2 = Program Event 2 or.bo = Out-of-range or burn out indicator P.FAL = Power failure indicator bo.PF = Out-of-range, burn out and Power failure indicator diF.1 = The output repeats the digital input 1 status diF.2 = The output repeats the digital input 2 status St.bY = Stand by status indicator	H.reg	A-16
13	o1AL	Alarms linked up with the out 1	0	from 0 to 15 +1 = Alarm 1 +2 = Alarm 2 +4 = Alarm 3 +8 = Loop break alarm	AL1	A-17
14	o1Ac	Out 1 action	0	dir = Direct action rEU = Reverse action dir.r = Direct with reversed LED ReU.r = Reverse with reversed LED	dir	C-0
15	o2F	Out 2 function	0	NonE = Output not used H.rEG = Heating output c.rEG = Cooling output AL = Alarm output t.out = Timer output t.HoF = Timer out -OFF in hold P.End = Program end indicator P.HLd = Program hold indicator P. uit = Program wait indicator P.run = Program run indicator P.Et1 = Program Event 1 P.Et2 = Program Event 2 or.bo = Out-of-range or burn out indicator P.FAL = Power failure indicator bo.PF = Out-of-range, burn out and Power failure indicator diF.1 = The output repeats the digital input 1 status diF.2 = The output repeats the digital input 2 status St.bY = Stand by status indicator	AL	A-19
16	o2AL	Alarms linked up with the out 2	0	From 0 to 15 +1 = Alarm 1 +2 = Alarm 2 +4 = Alarm 3 +8 = Loop break alarm	AL1	A-20

n°	Parameter	Description	Dec.	Range	Def.	Vis. Promo.
17	o2Ac	Out 2 action	0	dir = Direct action rEU = Reverse action dir.r = Direct with reversed LED ReU.r = Reverse with reversed LED	dir	C-0
18	o3F	Out 3 function	0	NonE = Output not used H.rEG = Heating output c.rEG = Cooling output AL = Alarm output t.out = Timer output t.HoF = Timer out -OFF in hold P.End = Program end indicator P.HLd = Program hold indicator P. uit = Program wait indicator P.run = Program run indicator P.Et1 = Program Event 1 P.Et2 = Program Event 2 or.bo = Out-of-range or burn out indicator P.FAL = Power failure indicator bo.PF = Out-of-range, burn out and Power failure indicator diF.1 = The output repeats the digital input 1 status diF.2 = The output repeats the digital input 2 status St.bY = Stand by status indicator	AL	A-22
19	o3AL	Alarms linked up with the out 3	0	From 0 to 15 +1 = Alarm 1 +2 = Alarm 2 +4 = Alarm 3 +8 = Loop break alarm	AL2	A-23
20	o3Ac	Out 3 action	0	dir = Direct action rEU = Reverse action dir.r = Direct with reversed LED ReU.r = Reverse with reversed LED	dir	C-0
21	o4F	Out 4 function	0	NonE = Output not used H.rEG = Heating output c.rEG = Cooling output AL = Alarm output t.out = Timer output t.HoF = Timer out -OFF in hold P.End = Program end indicator P.HLd = Program hold indicator P. uit = Program wait indicator P.run = Program run indicator P.Et1 = Program Event 1 P.Et2 = Program Event 2 or.bo = Out-of-range or burn out indicator P.FAL = Power failure indicator bo.PF = Out-of-range, burn out and Power failure indicator diF.1 = The output repeats the digital input 1 status diF.2 = The output repeats the digital input 2 status St.bY = Stand by status indicator	AL	A-24
22	o4AL	Alarms linked up with the out 4	0	From 0 to 15 +1 = Alarm 1 +2 = Alarm 2 +4 = Alarm 3 +8 = Loop break alarm	AL2	A-25
23	o4Ac	Out 4 action	0	dir = Direct action rEU = Reverse action dir.r = Direct with reversed LED ReU.r = Reverse with reversed LED	dir	C-0

n°	Parameter	Description	Dec.	Range	Def.	Vis. Promo.
24	o5F	Out 5 function	0	NonE = Output not used H.rEG = Heating output c.rEG = Cooling output AL = Alarm output t.out = Timer output t.HoF = Timer out -OFF in hold P.End = Program end indicator P.HLd = Program hold indicator P.uit = Program wait indicator P.run = Program run indicator P.Et1 = Program Event 1 P.Et2 = Program Event 2 or.bo = Out-of-range or burn out indicator P.FAL = Power failure indicator bo.PF = Out-of-range, burn out and Power failure indicator diF.1 = The output repeats the digital input 1 status diF.2 = The output repeats the digital input 2 status St.bY = Stand by status indicator	AL	C-0
25	o5AL	Alarms linked up with the out 3	0	From 0 to 15 +1 = Alarm 1 +2 = Alarm 2 +4 = Alarm 3 +8 = Loop break alarm	AL2	C-0
26	o5Ac	Out 5 action	0	dir = Direct action rEU = Reverse action dir.r = Direct with reversed LED ReU.r = Reverse with reversed LED	dir	C-0

AL1 group

n°	Parameter	Description	Dec.	Range	Def.	Vis. Promo.
27	AL1t	Alarm 1 type	0	nonE = Alarm not used LoAb = Absolute low alarm HiAb = Absolute high alarm LHAb = Absolute band alarm LodE = Deviation low alarm (relative) HidE = Deviation high alarm (relative) LHdE = Relative band alarm	LoAb	A-47
28	Ab1	Alarm 1 function	0	From 0 to 15 +1 = Not active at power up +2 = Latched alarm (manual reset) +4 = Acknowledgeable alarm +8 = Relative alarm not active at set point change	0	C-0
29	AL1L	- For High and low alarms, it is the low limit of the AL1 threshold - For band alarm, it is low alarm threshold	dP	From -1999 to AL1H (E.U.)	-1999	A-48
30	AL1H	- For High and low alarms, it is the high limit of the AL1 threshold - For band alarm, it is high alarm threshold	dP	From AL1L to 9999 (E.U.)	9999	A-49
31	AL1	AL1 threshold	dP	From AL1L to AL1H (E.U.)	0	A-50
32	HAL1	AL1 hysteresis	dP	From 1 to.9999 (E.U.)	1	A-51
33	AL1d	AL1 delay	dP	From 0 (oFF) to 9999 (s)	oFF	C-0
34	AL1o	Alarm 1 enabling during Stand-by mode	0	no = alarm 1 disabled during Stand-by YES = alarm 1 enabled during Stand-by	no	C-0

AL2 group

n°	Parameter	Description	Dec.	Range	Def.	Vis Promo.
35	AL2t	Alarm 2 type	0	nonE = Alarm not used LoAb = Absolute low alarm HiAb = Absolute high alarm LHAb = Absolute band alarm LodE = Deviation low alarm (relative) HidE = Deviation high alarm (relative) LHdE = Relative band alarm	HiAb	A-54
36	Ab2	Alarm 2 function	0	From 0 to 15 +1 = Not active at power up +2 = Latched alarm (manual reset) +4 = Acknowledgeable alarm +8 = Relative alarm not active at set point change	0	C-0
37	AL2L	- For High and low alarms, it is the low limit of the AL2 threshold - For band alarm, it is low alarm threshold	dP	From -1999 to AL2H (E.U.)	-1999	A-56
38	AL2H	- For High and low alarms, it is the high limit of the AL2 threshold - For band alarm, it is high alarm threshold	dP	From AL2L to 9999 (E.U.)	9999	A-57
39	AL2	Alarm 2 threshold	dP	From AL2L to AL2H (E.U.)	0	A-58
40	HAL2	Alarm 2 hysteresis	dP	From 1 to 9999 (E.U.)	1	A-59
41	AL2d	Alarm 2 delay	dP	From 0 (oFF) to 9999 (s)	oFF	C-0
42	AL2o	Alarm 2 enabling during Stand-by mode	0	no = alarm 2 disabled during Stand-by YES = alarm 2 enabled during Stand-by	no	C-0

AL3 group

n°	Parameter	Description	Dec.	Range	Def.	Vis Promo.
43	AL3t	Alarm 3 type	0	nonE = Alarm not used LoAb = Absolute low alarm HiAb = Absolute high alarm LHAb = Absolute band alarm LodE = Deviation low alarm (relative) HidE = Deviation high alarm (relative) LHdE = Relative band alarm	nonE	C-0
44	Ab3	Alarm 3 function	0	From 0 to 15 +1 = Not active at power up +2 = Latched alarm (manual reset) +4 = Acknowledgeable alarm +8 = Relative alarm not active at set point change	0	C-0
45	AL3L	- For High and low alarms, it is the low limit of the AL3 threshold - For band alarm, it is low alarm threshold	dP	From -1999 to AL3H (E.U.)	-1999	C-0
46	AL3H	- For High and low alarms, it is the high limit of the AL3 threshold - For band alarm, it is high alarm threshold	dP	From AL3L to 9999 (E.U.)	9999	C-0
47	AL3	Alarm 3 threshold	dP	From AL3L to AL3H (E.U.)	0	C-0
48	HAL3	Alarm 3 hysteresis	dP	From 1 to 9999 (E.U.)	1	C-0
49	AL3d	Alarm 3 delay	dP	From 0 (oFF) to 9999 (s)	oFF	C-0
50	AL3o	Alarm 3 enabling during Stand-by mode	0	no = alarm 2 disabled during Stand-by YES = alarm 2 enabled during Stand-by	no	C-0

LbA group

n°	Parameter	Description	Dec.	Range	Def.	Vis Promo.
51	LbAt	LBA time	0	From 0 (oFF) to 9999 (s)	oFF	C-0
52	LbSt	Delta measure used by LBA during Soft start.	dP	From 0 (oFF) to 9999 (E.U.)	10	C-0
53	LbAS	Delta measure used by LBA	dP	From 1 to 9999 (E.U.)	20	C-0
54	LbcA	Condition for LBA enabling	0	uP = Active when Pout = 100% dn = Active when Pout = -100% both = Active in both cases	both	C-0

rEG group

n°	Parameter	Description	Dec.	Range	Def.	Vis Promo.
55	cont	Control type	0	Pid = PID (heat and/or cool) On.FA = ON/OFF asymmetric hysteresis On.FS = ON/OFF symmetric hysteresis nr = Heat/Cool ON/OFF control with neutral zone	Pid	A-25
56	Auto	Autotuning selection	0	-4 = Oscillating auto-tune with automatic restart at power up and after all set point change -3 = Oscillating auto-tune with manual start -2 = Oscillating auto-tune with auto-matic start at the first power up only -1 = Oscillating auto-tune with auto-matic restart at every power up 0 = Not used 1 = Fast auto tuning with automatic restart at every power up 2 = Fast auto-tune with automatic start at the first power up only 3 = FAST auto-tune with manual start 4 = FAST auto-tune with automatic restart at power up and after a set point change	2	C-0
57	Aut.r	Manual start of the Autotuning	0	oFF = Not active on = Active	oFF	A-26
58	SELF	Self tuning enabling	0	oFF = The instrument do not perform the self-tuning on = The instrument is performing the self-tuning	no	C-0
59	HSEt	Hysteresis of the ON/OFF control	dP	From 0 to 9999 (E.U.)	1	A-27
60	cPdt	Time for compressor protection	0	From 0 (oFF) to 9999 (s)	oFF	C-0
61	Pb	Proportional band	dP	From 0 to 9999 (E.U.)	50	A-28
62	int	Integral time	0	From 0 (oFF) to 9999 (s)	200	A-29
63	dEr	Derivative time	0	From 0 (oFF) to 9999 (s)	50	A-30
64	Fuoc	Fuzzy overshoot control	2	From 0.00 to 2.00	0.50	A-31
65	H.Act	Heating output actuator	0	SSr = SSR rELY = relay SLou = slow actuators	SSr	A-32
66	tcrH	Heating output cycle time	1	From 0.1 to 130.0 (s)	20.0	C-0
67	PrAt	Power ratio between heating and cooling action	2	From 0.01 to 99.99	1.00	A-34
68	c.Act	Cooling output actuator	0	SSr = SSR rELY = relay SLou = slow actuators	SSr	A-35
69	tcrc	Cooling output cycle time	1	From 0.1 to 130.0 (s)	20.0	C-0
70	rS	Manual reset (Integral pre-load)	1	From -100.0 to 100.0 (%)	0.0	C-0
71	roh.L	Minimum power for heating outputs	0	0 ÷ roh.h (%)		

n°	Parameter	Description	Dec.	Range	Def.	Vis. Promo.
72	roh.h	Maximum power for heating outputs	0	roh.L ÷ 100 (%)		
73	roc.L	Minimum power for cooling outputs	0	0 ÷ roc.h (%)		
74	roc.h	Maximum power for cooling outputs	0	roc.L ÷ 100 (%)		
75	oPSh	Heating output max rate of rise	0	1 ÷ 51 (inF) %/s		
76	oPSc	Cooling output max rate of rise	0	1 ÷ 51 (inF) %/s		
77	thrh	Power threshold at which output H.rEG begins to operate.	0	-50 ÷ 50 (%)		
78	thrc	Power threshold at which output C.rEG begins to operate.	0	-50 ÷ 50 (%)		
79	od	Delay at power up	2	From 0.00 (oFF) to 99.59 (hh.mm)	oFF	C-0
80	St.P	Maximum power output used during soft start	0	From -100 to 100 (%)	0	C-0
81	SSt	Soft start time	2	From 0.00 (oFF) to 8.00 (inF) (hh.mm)	oFF	C-0
82	SStH	Threshold for soft start disabling	dP	From -1999 to 9999 (E.U.)	9999	C-0

SP Group

n°	Parameter	Description	Dec.	Range	Def.	Vis. Promo.
83	nSP	Number of used set points	0	From 1 to 4	1	A-38
84	SPLL	Minimum set point value	dP	From -1999 to SPHL	-1999	A-39
85	SPHL	Maximum set point value	dP	From SPLL to 9999	9999	A-40
86	SP 1	Set point 1	dP	From SPLL to SPLH	0	O-41
87	SP 2	Set point 2	dP	From SPLL to SPLH	0	O-42
88	SP 3	Set point 3	dP	From SPLL to SPLH	0	O-43
89	SP 4	Set point 4	dP	From SPLL to SPLH	0	O-44
90	SPAt	Selection of the active set point.	0	From 1 (SP 1) to nSP	1	O-45
91	SP.rt	Remote set point type	0	RSP = The value coming from serial link is used as remote set point trin = The value will be added to the local set point selected by SPAt and the sum becomes the operative set point PErc = The value will be scaled on the input range and this value will be used as remote set point	trin	C-0
92	SP.Lr	Local/remote set point selection	0	Loc = local rEn = remote	Loc	C-0
93	SP.u	Rate of rise for POSITIVE set point change	2	From 0.01 to 100.00 (inF) Engineering units per minute	inF	C-0
94	SP.d	Rate of rise for NEGATIVE set point change	2	0.01 ÷ 100.00 (inF) Engineering units per minute	inF	C-0

Tin Group

n°	Parameter	Description	Dec.	Range	Def.	Vis. Promo.
95	tr.F	Independent timer function	0	NonE = Timer not used i.d.A = Delayed start timer i.uP.d = Delayed start at power up i.d.d = Feed-through timer i.P.L = Asymmetrical oscillator with start in OFF i.L.P = Asymmetrical oscillator with start in ON	nonE	A-62
96	tr.u	Timer unit	0	hh.nn = Hours and minutes nn.SS = Minutes and seconds SSS.d = Second and tenth of seconds	nn.SS	A-63

n°	Parameter	Description	Dec.	Range	Def.	Vis. Promo.
97	tr.t1	Time 1	2 1	From 00.01 to 99.59 when tr.u < 2 From 000.1 to 995.9 when tr.u = 2	1.00	A-64
98	tr.t2	Time 2	2 1	When tr.u < 2: From 00.00 (oFF) to 99.59 (inF) When tr.u = 2: From 000.0 (oFF) to 995.9 (inF)	1.00	A-65
99	tr.St	Timer status	0	rES = timer reset run = timer run HoLd = timer hold	rES	C-0

PrG Group

n°	Parameter	Description	Dec.	Range	Def.	Vis. Promo.
100	Pr.F	Program action at power up	0	nonE =Programmer not used S.uP.d = Start at power up with a first step in stand-by S.uP.S = Start at power up u.diG = Start at Run command detection only u.dG.d = Start at Run command with a first step in stand-by	nonE	A-67
101	Pr.u	Engineering unit of the soak	2	hh.nn = Hours and minutes nn.SS = Minutes and seconds	hh.nn	A-68
102	Pr.E	Instrument behaviour at the end of the program execution.	0	cnt = continue SPAt = go to the set point selected by SPAt St.by = go to stand-by mode	SPAt	A-71
103	Pr.Et	Time of the end program indication	2	From 0.00 (oFF) to 100.00 (inF) minutes and seconds	oFF	A-72
104	Pr.S1	Set point of the first soak	dP	From SPLL to SPHL	0	A-73
105	Pr.G1	Gradient of the first ramp	1	From 0.1 to 1000.0 (inF= Step transfer) Engineering Unit/minute	inF	A-74
106	Pr.t1	Time of the first soak	2	From 0.00 to 99.59	0.10	A-75
107	Pr.b1	Wait band of the first soak	dP	From 0 (oFF) to 9999 (E.U.)	oFF	A-76
108	Pr.E1	Events of the first group	2	From 00.00 to 11.11	00.00	C-0
109	Pr.S2	Set point of the second soak	dP	OFF or from SPLL to SPHL	0	A-78
110	Pr.G2	Gradient of the second ramp	1	From 0.1 to 1000.0 (inF= Step transfer) Engineering Unit/minute	inF	A-79
111	Pr.t2	Time of the second soak	2	From 0.00 to 99.59	0.10	A-80
112	Pr.b2	Wait band of the second soak	dP	From 0 (oFF) to 9999 (E.U.)	oFF	A-81
113	Pr.E2	Events of the second group	2.	From 00.00 to 11.11	00.00	C-0
114	Pr.S3	Set point of the third soak	dP	OFF or from SPLL to SPHL	0	A-83
115	Pr.G3	Gradient of the third ramp	1	From 0.1 to 1000.0 (inF= Step transfer) Engineering Unit/minute	inF	A-84
116	Pr.t3	Time of the third soak	2	From 0.00 to 99.59	0.10	A-85
117	Pr.b3	Wait band of the third soak	dP	From 0 (oFF) to 9999 (E.U.)	oFF	A-86
118	Pr.E3	Events of the third group	0	From 00.00 to 11.11	00.00	C-0
119	Pr.S4	Set point of the fourth soak	dP	OFF or from SPLL to SPHL	0	A-88
120	Pr.G4	Gradient of the fourth ramp	1	From 0.1 to 1000.0 (inF= Step transfer) Engineering Unit/minute	inF	A-89
121	Pr.t4	Time of the fourth soak	2	From 0.00 to 99.59	0.10	A-90
122	Pr.b4	Wait band of the fourth soak	dP	From 0 (oFF) to 9999 (E.U.)	oFF	A-91
123	Pr.E4	Events of the fourth group	0	From 00.00 to 11.11	00.00	C-0

n°	Parameter	Description	Dec.	Range	Def.	Vis. Promo.
124	Pr.St	Program status	0	rES = Program reset run = Program start HoLd = Program hold	0	C-0

Pan Group

n°	Parameter	Description	Dec.	Range	Def.	Vis. Promo.
125	PAS2	Password level 2	0	From 0 (oFF) to 999	20	A-93
126	PAS3	Password level 3	0	From 1 to 999	30	C-0
127	uSrb	U button function during run time	0	nonE = Not used tunE = Starts auto tuning functions oPLo = Manual mode (OPLO) AAc = Alarm reset ASi = Alarm acknowledge chSP = Sequential set point selection St.by = Stand-by mode Str.t = Run/hold/reset timer P.run = Program start P.rES = program reset P.r.H.r = Run/hold/reset program	nonE	A-94
128	diSP	Display management	0	nonE = Standard display Pou = Power output SPF = Final set point Spo = Operative set point AL1 = Alarm 1 threshold AL2 = Alarm 2 threshold AL3 = Alarm 3 threshold Pr.tu = Program time up Pr.td = Program time down P.t.tu = Program total time up P.t.td = Program total time down ti.uP = Timer time up ti.du = Timer time down	nonE	A-95
129	AdE	Bargraph deviation	dP	From 0 (oFF) to 9999	2	A-96
130	FiLd	Filter on the displayed value	1	From 0.0(oFF) to 20.0	oFF	C-0
131	dSPu	Status of the instrument at power up	0	AS.Pr = Starts in the same way it was prior to the power down Auto = Starts in Auto mode oP.0 = Starts in manual mode with a power output equal to zero St.bY = Starts in stand-by mode	AS.Pr	C-0
132	oPr.E	Operative mode enabling	0	ALL = All Au.oP = Autp or manual (oPLo) only Au.Sb = Auto and Stand by only	ALL	C-0
133	oPEr	Operative mode selection	0	Auto = Automatic oPLo = Manual St.by = Stand-by	Auto	O-1

Ser group

n°	Parameter	Description	Dec.	Range	Def.	Vis. Promo.
134	Add	Address	0	0 (oFF) ÷ 254	1	C-0
135	bAud	Baud rate	0	1200 2400 9600 19.2 38.4	9600	C-0

n°	Parameter	Description	Dec.	Range	Def.	Vis. Promo.
136	trSP	Selection of the value to be retransmitted (Master)	0	nonE = Not used rSP = Operative set point PErc = Current power output (%)	nonE	C-0

con group (Wattmeter)

n°	Parameter	Description	Dec.	Range	Def.	Vis. Promo.
137	co.ty	Measurement type	0	oFF = Not used 1 = Instantaneous power (kW) 2 = Power consumption (kW/h) 3 = Energy used during program execution 4 = Total worked days with threshold 5 = Total worked hours with threshold	nonE	A-97
138	UoLt	Nominal voltage of the load	0	From 1 to 999 (Volt)	230	A-98
139	cur	Nominal current of the load	0	From 1 to 999 (A)	10	A-99
140	h.Job	Threshold of the worked hours/days	0	From 0(oFF) to 9999	oFF	A-100

CAL Group (User calibration)

n°	Parameter	Description	Dec.	Range	Def.	Vis. Promo.
141	A.L.P	Adjust low Point	dP	From -1999 to AH.P-10 (E.U.)	0	A-9
142	A.L.o	Adjust low Offset	dP	From -300 to 300 (E.U.)	0	A-10
143	A.H.P	Adjust High Point	dP	From A.L.P +10 to 9999 (E.U.)	9999	A-11
144	A.H.o	Adjust High Offset	dP	From -300 to 300 (E.U.)	0	A-12

APPENDIX B**K 30 Communication protocol**

INDEX

1 Preface	4
2 Physical connection	5
2.1 Interface.....	5
2.2 Line.....	5
3 Communication protocol.....	6
3.1 Function 3 - read n word.....	7
3.2 Function 6 - one word write.....	8
3.3 The exception replay.....	9
3.4 Cyclic redundancy check (CRC).....	10
4 Data exchange.....	12
4.1 Some definitions.....	12
4.2 Memory zones.....	13
4.2.1 Variables zones.....	13
4.2.2 Parameters programming	15
4.2.3 Identification code zone.....	25
5 Performance.....	25

1 Preface

Tecnologic uses ModBUS® RTU communication protocol.
It is a royalty free protocol and it is easy to implement.
For ModBus RTU a vast literature is available also in internet.

The ModBus protocol represent all data in hexadecimal format.
All communication string finish with a check sum type CRC (cyclic redundancy [check](#)).
Every devices in a line must have different address.
The protocol allows one master only and up to 255 slaves
Only Master unit can start the transmission by sending the address of the unit and the command to execute.
Only the unit having the same address will answer to the master.

The transmission characteristics are usually programmable:

- Device address: from 1 to 255
 - Baud rate: bit per second
 - byte format:
 - 1 start bit
 - 8 data bitis
 - 2 final bits composed as follows:
 - 1 parity bit (even or odd)
 - 1 stop bit
- or
- no parity bit
 - 2 stop bits

The K30 allows to configure:

- address (1 – 254)
- Baud rate (1200 – 2400 – 9600 – 19200 – 38400)

The byte format is fixed : 8 bits without parity and 1 stop bit

This document is intended to describe the K 30 controllers using the MODBUS protocol in their communication capability and is mainly directed to technicians, system integrators and software developers.

2 Physical connection

Interface

K series controllers are provided with a RS485 serial communication interface, insulated so that any problem arising from ground potential is removed.

While at rest, the instruments are in a receive condition and are revert to transmission after a correct message has been decoded that matches the configured address.

Line

The instruments are equipped with 2 terminals named A and B.
The connection between TLKs has to be carried on in parallel, i.e. all A terminals have to be connected between them so as B terminals.

A termination resistor of 120 ohm is required to maintain the quiescent condition on the line;
Adopted baud rates range from 1200 to 38400 baud, that is very satisfactory for application performances, yet very slow for RS485 interface. This fact allows the wiring of the line with a medium quality twisted pair cable: total capacity of the line should not exceed 200 nF.

The line can be up to 1000 meters in length.

3 Communication protocol

The protocol adopted by K 30 is a subset of the widely used MODBUS RTU (JBUS)¹ protocol, so that connections are easy for many commercial PLCs and supervisory programs.

For users needing to develop their own communication software, all information is available as well as implementation hints.

The MODBUS RTU (JBUS) communication functions implemented in K series are:

- Function 3 - read n register
- Function 6 - preset one register .
- Function 16 – preset multiple register

These functions allow the supervisory program to read and modify any data of the controller.

The communication is based on messages sent by the master station (host) to the slave stations (K 30) and viceversa.

The slave station that recognises the message as sent to it, analyses the content and, if it is formally and semantically correct, generates a reply message directed back to the master.

The communication process involves five types of messages:

from master to slave	from slave to master
function 3: read n registers request	function 3: read n registers reply
function 6: preset one register request	function 6: preset one register reply
function 16: preset multiple registers request	Function 16: preset multiple registers reply
	exception reply (as reply to all functions in abnormal conditions)

Every a message contains four fields:

- slave address (from 1 to 255): MODBUS RTU (JBUS) reserves address 0 for broadcasting messages and it is implemented in the K series;
- function code: contains 3, 6 or 16 for specified functions;
- information field: contains data like word addresses and word values as required by function in use;
- control word: a cyclic redundancy check (CRC) performed with particular rules for CRC16.

The characteristics of the asynchronous transmission are 8 bits, no parity, one stop bit.

¹ AEG Schneider Automation, Inc. registered trade mark

Function code 3: read multiple registers (maximum 16 registers for K30)

This function code is used by the master to read a group of sequential registers present in the slave.

Master request		Slave reply	
Data	Byte	Data	Byte
Slave address (1-255)	1	Slave address (1-255)	1
Function code (3)	1	Function code (3)	1
First register address (MSB = Most Significant Byte)	1	Byte number (n)	1
First register address (LSB = less Significant Byte)	1	Data(s)	n
Number of requested registers (MSB)	1	CRC-16 (LSB)	1
Number of requested registers (LSB)	1	CRC-16 (MSB)	1
CRC-16 (LSB)	1		
CRC-16 (MSB)	1		

In the "Data(s)" field the values of the requested registers are presented in word format [2 byte] : the first byte represent the MSB (Most Significant Byte) while the second byte represent the LSB (Less Significant Byte). This mode will be the same for all requested locations.

Example:

The master requires to the address 1 the value of the locations 25 and 26 (0x19 and 0x1A).

Master request		Slave reply	
Data	Byte (Hex)	Data	Byte (Hex)
Slave address	01	Slave address	01
Function code (3 = read)	03	Function code (3 = read)	03
First register address (MSB)	00	Byte number	04
First register address (LSB)	19	Value of the first register (MSB)	00
Number of requested registers (MSB)	00	Value of the first register (LSB)	0A
Number of requested registers (LSB)	02	Value of the second register (MSB)	00
CRC-16 (LSB)	15	Value of the second register (LSB)	14
CRC-16 (MSB)	CC	CRC-16 (LSB)	DA
		CRC-16 (MSB)	3E

The slave replay means:

The value of the location 25 = 10 (0x000A hexadecimal)

The value of the location 26 = 20 (0x0014 hexadecimal)

Function code 6: write a single word (one location)

Master request	
Data	Byte
Slave address (1-255)	1
Function code (6)	1
Register address (MSB)	1
Register address (LSB)	1
Value to write (MSB)	1
Value to write (LSB)	1
CRC-16 (MSB)	1
CRC-16 (LSB)	1

Slave reply	
Data	Byte
Slave address (1-255)	1
Function code (6)	1
Register address (MSB)	1
Register address (LSB)	1
Written value (MSB)	1
Written value (LSB)	1
CRC-16 (MSB)	1
CRC-16 (LSB)	1

Example:

The master unit asks to the slave 1 to write in the memory location 770 (0x302) the value 10 (0x0A).

Master request	
Data	Byte (Hex)
Slave address	01
Function code (6)	06
Register address (MSB)	03
Register address (LSB)	02
Value to write (MSB)	00
Value to write (LSB)	0A
CRC-16 (MSB)	A8
CRC-16 (LSB)	49

Slave reply	
Data	Byte (Hex)
Slave address	01
Function code (6)	06
Register address (MSB)	03
Register address (LSB)	02
Written value (MSB)	00
Written value (LSB)	0A
CRC-16 (MSB)	A8
CRC-16 (LSB)	49

Function code 16: preset multiple registers (maximum 16 registers for K30)

This function code allows to preset 16 registers at a time.

Master request	
Data	Byte
Slave address (1-254)	1
Function code (16)	1
First register address (MSB)	1
First register address (LSB)	1
Number of requested registers (MSB)	1
Number of requested registers (LSB)	1
Byte count	1
Values	n
CRC-16 (LSB)	1
CRC-16 (MSB)	1

Slave reply	
Data	Byte
Slave address (1-254)	1
Function code (16)	1
First register address (MSB)	1
First register address (LSB)	1
Number of written registers (MSB)	1
Number of written registers (LSB)	1
CRC-16 (LSB)	1
CRC-16 (MSB)	1

Example:

The master unit requires to the slave 1 to write in the registers 10314 (0x284A) and 10315 (0x284B) the values 100 (0x64) and 200 (0xC8)

Master request	
Data	Byte (Hex)
Slave address	01
Function code (16)	10
First register address (MSB)	28
First register address (LSB)	4A
Number of requested registers (MSB)	00
Number of requested registers (LSB)	02
Byte count	4
Value 1 (MSB)	00
Value 1 (LSB)	64
Value 2 (MSB)	00
Value 2 ((LSB)	C8
CRC-16 (LSB)	C9
CRC-16 (MSB)	A8

Slave reply	
Data	Byte (Hex)
Slave address	01
Function code (16)	10
First register address (MSB)	28
First register address (LSB)	4A
Number of written registers (MSB)	00
Number of written registers (LSB)	02
CRC-16 (LSB)	69
CRC-16 (MSB)	BE

The exception reply

K 30 instruments reply with an exception when the request is formally correct, but cannot be satisfied standing particular situations; the reply contains a code indicating the cause of the missing regular reply, the frame is:

Exception reply	
Data	Byte
Slave address	1
Function code	1
Error code	1
CRC-16 (LSB)	1
CRC-16 (MSB)	1

K 30 adopts a subset of MODBUS RTU (JBUS) exception code:

- unknown function code 1
- invalid memory address 2
- invalid data field 3
- controller not ready 6

Cyclic redundancy check (CRC)

CRC is a check word that permits to verify the integrity of a message.
Every message, sent or received, has in the two last characters the CRC check word.

After receiving a request, the controller checks the validity of the received message comparing the received CRC with the calculated one.

When a reply is ready the controller calculates the CRC word and adds two characters to the prepared message.

CRC calculation is performed on every character of the message, excluding the last two.

Being MODBUS RTU (JBUS) compatible, K series controllers adopt an identical algorithm for CRC calculation, sketched in following diagram:

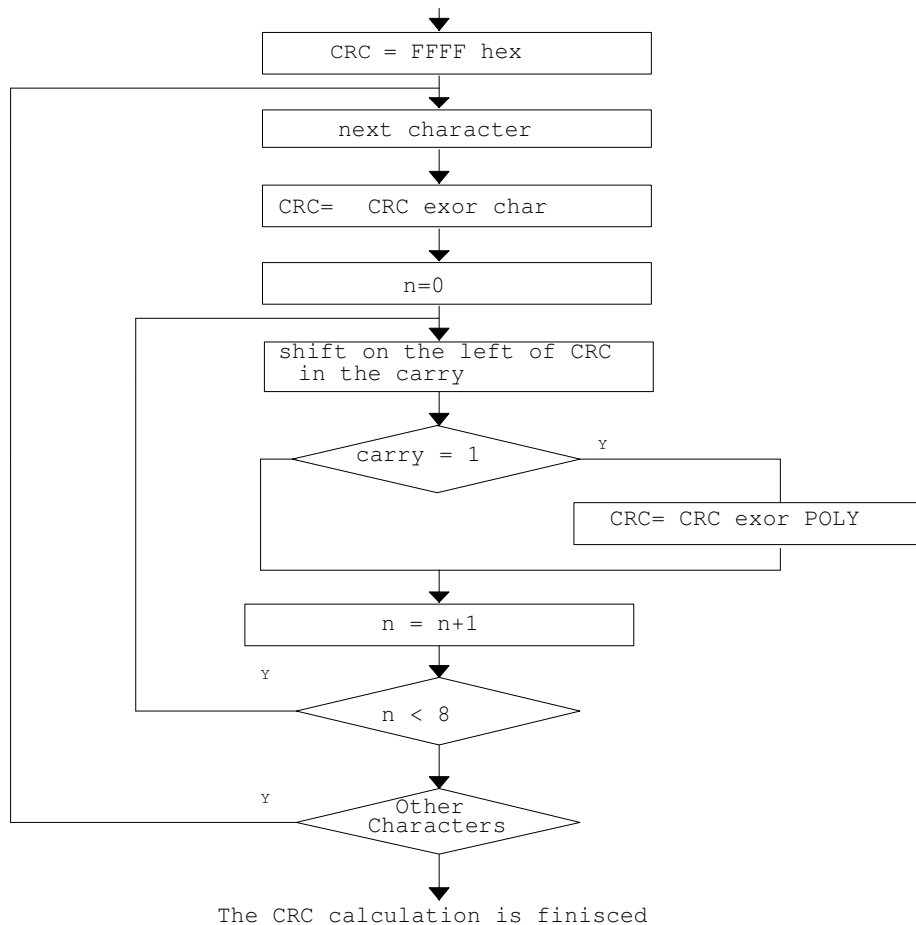

The polynomial adopted by MODBUS RTU (JBUS) is 1010 0000 0000 0001.

Note: the first transmitted character of the CRC word is the least significant between calculated bytes.

Follows a subroutine made with "C" able to calculate the CTC-16.

```

/* -----
crc_16      calcolo del crc_16

Parametri di ingresso:
  buffer: stringa di caratteri di cui calcolare il CRC-16
  length: numero di bytes della stringa

Questa funzione ritorna il valore di CRC-16
----- */
unsigned int crc_16 (unsigned char *buffer, unsigned int length)

```

```
{
    unsigned int i, j, temp_bit, temp_int, crc;

    crc = 0xFFFF;

    for ( i = 0; i < length; i++ ) {
        temp_int = (unsigned char) *buffer++;

        crc ^= temp_int;

        for ( j = 0; j < 8; j++ ) {
            temp_bit = crc & 0x0001;

            crc >>= 1;

            if ( temp_bit != 0 )
                crc ^= 0xA001;
        }
    }
    return (crc);
}
```

Note: all numerical values in the format 0x... are expressed in hexadecimal format.

4 Data exchange

This section contains informations about data exchanged with TLK series controllers concerning numerical and not numerical data, with their formats and limits.

Some definitions

All exchanged data are in the form of 16 bit words.

Two types of data are distinguished: numerical and symbolic (or not numerical).

Numerical data represents the value of a quantity (e.g. the measured variable, the set point).

Symbolic data represents a particular value in a set of values (e.g. the thermocouple type in the set of available ones : J,K,S...).

Both types are coded as integers number : signed numbers for numerical and unsigned numbers for symbolic.

A numerical data, coded as an integer, is coupled with appropriate number of decimal digits to represent a quantity with the same engineering units adopted aboard the instrument.

Numerical data are in fixed point representation; however we make a distinction between two kinds of data:

- the first kind has determined and unmodifiable decimal point position;
- the second has programmable decimal point position (dP parameter).

Memory zones

All readable and writable data appear to be allocated as 16 bit words in the memory of the instrument.

The memory map has three zones:

- variables,
- parameters,
- instrument identification code.

Following parameters explore the characteristics of each zone.

4.1 Variables zones

In this zone there is a collection of main TLK controller variables, it is a group of frequently computed or updated data residing in volatile memory.

MOST IMPORTANT CHANGE

A) during parameter modification **by push-button**, the serial interface continue to operate without any "limit" (you can see by serial link the value of all parameters and you can set it also)

B) When you write a value in a location the instrument will operate as follows:

B.1) if you write a value within parameter range, the instrument will accept it; the new value will be memorized and the instrument will send back the standard answer.

B.2) If you try to write a value OUT of parameter range, the instrument will refuse the new value; the new value will NOT be memorized and the instrument will send an exception message to the master.

These are available data:

5 Address map

All K instruments use only words :

Initial address		Final address		mining
Hex	Dec	Hex	Dec	
1	1	13	21	Group of variables common to all new Tecnologic's instruments.
200	512	250	592	Group of variables compatible with the old Tecnologic's instruments (before K series)
280	640	31B	795	Configuration parameters
2800	10240	2891	10385	Repetition of the configuration parameters. It was added in order to maintain the compatibility with the older Tecnologic's products.

n.	Address		Description	Dec	r/w
	HEX	Dec.			
1A	1	1	PV : Measured value Note: When a measuring error is detected the instrument send: -10000 = Underrange 10000 = Overage 10001 = Overflow of the A/D converter 10003 = Variable not available	dP	r
2A	2	2	Number of decimal figures of the measured value		r
3A	3	3	Operative set point (value)	dP	r
4A	4	4	Power output Range: -100.00 ÷ 100.00 (%) Note: This parameter is ever writeable but it will be active only when the instrument operate in Manual mode.	2	r/w
5A	5	5	Active set point selection 0 = SP 1 1 = SP 2 2 = SP 3 3 = SP 4	0	r/w
6A	6	6	SP 1 Range: SPLL ÷ SPLH	dP	r/w
7A	7	7	SP 2 Range: SPLL ÷ SPLH	dP	r/w
8A	8	8	SP 3 Range: SPLL ÷ SPLH	dP	r/w
9A	9	9	SP 4 Range: SPLL ÷ SPLH	dP	r/w
10A	A	10	Alarms status bit 0 = Alarm 1 status bit 1 = Alarm 2 status bit 2 = Alarm 3 status bit 3÷8 = reserved bit 9 = LBA status bit 10 = power feilure indicator bit 11 = Generic error bit 12÷15 = reserved	0	r
11A	B	11	Outputs status (physical outputs) bit 0 = Output 1 status bit 1 = Output 2 status bit 3 = Output 3 status bit 4 = Output 4 status bit 5 = Output 5 status bit 6÷15 = Reserved When an output is driven by serial link, the relative bit will remain equal to 0.	0	r

n.	Address		Description	Dec	r/w
	HEX	Dec.			
12A	C	12	Instrument status bit 0 = Automatic bit 1 = manual bit 2 = Standby bit 3 = Remote Set point (temporary) used bit 4 = Auto-tuning active bit 5 = Self tuning active bit 6 = Reserved bit 7 = Timer running bit 8 = Soft start running bit 9 = Ramp for set point change (up or down) running bit 10 = Delay at start up (od) running bit 11 = Program running bit 12 = Measure status (0 = OK while 1 = error). bit 13÷15 = Reserved	0	r
13A	D	13	Alarms reset 0 = Not resetted 1 = Resetted	0	r/w
14A	E	14	Alarms acknowledge 0 = Not acknowledge 1 = acknowledge	0	r/w
15A	F	15	Control status 0 = Automatic 1 = Manual 2 = Stand-by	0	r/w
16A	10	16	Remote set point (temporary) (from serial link) Range: SPLL ÷ SPLH Note: the remote set point is memorized in RAM	dP	r/w
17A	11	17	Auto tuning activation 0 = not active 1 = active	0	r/w
18A	12	18	Power output used when a measuring error is detected. Range: -100 ÷ 100 Note: This valie is memorized in RAM	0	r/w
19A	13	19	Default parameters loading. 481 = Default parameter loading	0	r/ w
20A	14	20	Parameters table identification code Range: 0 ÷ 65535 Note The word is composed by two parts: Low byte – Version of the parameter table High byte - Version of the family protocoll	0	r
21A	15	21	Instrument identification code 11 = K30	0	r

Group of variables compatible with the old Tecnologic's instruments (before K series)

n.	Address		Description	Dec	r/w
	HEX	Dec.			
1B	0200	512	PV : Measured value As address 1		
2B	0201	513	Number of decimal figure of the measured value As address 2		
3B	0202	514	Power output As address 4	2	r
4B	0203	515	Power output of the heating output Range: 0 ÷ 100.00 (%)	2	r
5B	0204	516	Power output of the cooling output Range: 0 ÷ 100.00 (%)	2	r
6B	0205	517	Alarm 1 status 0 = OFF 1 = ON	0	r
7B	0206	518	Alarm 2 status 0 = OFF 1 = ON	0	r
8B	0207	519	Alarm 3 status 0 = OFF 1 = ON	0	r
9B	0208	520	Operative set point As address 3		
10B	020A	522	LBA status 0 = OFF 1 = ON	0	r
11B	020F	527	Control status 0 = Automatic 1 = Manual 2 = Standby 3 = Tuning	0	r/w
12B	0224	548	Status / remote control of the Output 1 0 = OFF 1 = ON Note: This parameter is writeable when out 1 is "not used" by the controller (o1F output 1 function = nonE) This parameter is memorized in RAM	0	r/w
13B	0225	549	Status / remote control of the Output 2 0 = OFF 1 = ON Note: This parameter is writeable when out 2 is "not used" by the controller (o2F output 2 function = nonE) This parameter is memorized in RAM	0	r/w
14B	0226	550	Status / remote control of the Output 3 0 = OFF 1 = ON Note: This parameter is writeable when out 3 is "not used" by the controller (o3F output 3 function = nonE) This parameter is memorized in RAM	0	r/w

n.	Address		Description	Dec	r/w
	HEX	Dec.			
15B	0227	551	Status/remote control of the Output 4 0 = OFF 1 = ON Note: This parameter is writeable when out 4 is "not used" by the controller (o4F output 4 function = nonE) This parameter is memorized in RAM	0	r/w
16B	228	552	Status/remote control of the Output 5 0 = OFF 1 = ON Note: This parameter is writeable when out 5 is "not used" by the controller (o5F output 5 function = nonE) This parameter is memorized in RAM	0	r/w
17B	0240	576	Digital input 1 status 0 = OFF 1 = ON Note: The digital input 1 status shows its status even if the input is not used	0	r/w
18B	0241	577	Digital input 2 status 0 = OFF 1 = ON Note: The digital input 2 status shows its status even if the input is not used	0	r/w
19B	0244	580	Program status 0 = Not configured 1 = Reset (not running) 2 = Run 3 = Hold 4 = Wait 5 = End	0	r/w
20B	0245	581	Timer status 0 = Not configured 1 = Reset 2 = Run 3 = Hold 4 = End	0	r/w
21B	0246	582	Program step in execution 0 = Program not active 1 = ramp step 1 2 = soak step 1 2 = ramp step 2 4 = soak step 2 5 = ramp step 3 6 = soak step 3 7 = ramp step 4 8 = soak step 4 9 = END	0	r
22B	0247	583	Remaining time to the program end Range: 0 ÷ 65535 (when Pru=hh.mm the E.U. is minutes, when Pru=mm.ss the E.U. is seconds) Note: When the program is not running this parameter is equal to zero.	2	r
23B	248	584	Program events status 0 > E1 = 0 E2 = 0 1 > E1 = 1 E2 = 0 2 > E1 = 0 E2 = 1 3 > E1 = 1 E2 = 1	0	r

n.	Address		Description	Dec	r/w
	HEX	Dec.			
24B	249	585	Remaining time to the timer end Range: 0 ÷ 65535 (Hours when Tru=hh.mm, Minutes when Tru=mm.ss) 0 ÷ 9959 (tenth of seconds when Tru=SS.S.d) Note: When the timer is not active this parameter is equal to zero.	2 1	r
25B	24A	586	Wattmeter: The meaning of this parameter is defined by the CO.ty parameter setting. 0 CO.ty = 0ff KW CO.ty = 1 Kwh CO.ty = 2 Energy used during program execution (Kwh) CO.ty = 3 worked days CO.ty = 4 Worked hours CO.ty = 5	0	r
26B	24B	587	Time necessary to execute the first ramp of the program. Range: from 0 to 65535 (minute or seconds according to [101] P.ru parameter value)		
27B	250	592	Power output when the instrument is in manual mode Campo: -100.00 ÷ 100.00 (%)	2	r/w

Configuration parameters low address

inP group (Inputs parameters)

n.	Parameter	address		Mining	Values	Dec	r/w
		Hex	Dec				
1	HcFG	280	640	Built in Hardware	0 = 0 > TC/RTD 1 = 1 > TC/PTC 2 = 2 > Corrente 3 = 3 > Volt	0	r
2	SEnS	281	641	Input type Note: According to the built in hardware Hardware: TC, Pt100 TC, PTC, NTC Current (I) Voltage (V)	0 = J, 1 = crAL, 2 = S, 3 = r, 4 = t, 5 = ir.J, 6 = ir.cA, 7 = Pt1, 8 = 0.50 (mV), 9 = 0.60 (mV), 10 = 12.60 (mV) 0 = J, 1 = crAL, 2 = S, 3 = r, 4 = t, 5 = ir.J, 6 = ir.cA, 7 = Ptc, 8 = ntc, 9 = 0.50 (mV), 10 = 0.60 (mV), 11 = 12.60 (mV) 0 = 0.20 (mA), 1 = 4.20 (mA) 0 = 0.1 (V) 1 = 0.5(V), 2 = 1.5(V), 3 =0.10(V), 4 = 2.10(V)	0	r/w
3	dP	282	642	Decimal figures	0 ÷ 3 for linear inputs 0 ÷ 1 for TC, RTD, PTC, NTC	0	r/w
4	SSc	283	643	Initial scale readout for linear inputs	-1999 ÷ FSC (E.U.)	dP	r/w
5	FSc	284	644	Full scale readout for linear inputs	SSC ÷ 9999 (E.U.)	dP	r/w
6	unit	285	645	Engineering unit.	0 = C > °C 1 = F > °F	0	r/w
7	FiL	286	646	Digital input filter Note This filter affect the control, the retrasmission and the alarm actions.	0 = (oFF) ÷ 200	1	r/w
8	inE	287	647	Selection of the Sensor Out of Range type that will enable the safety output value	0 = our > Over and Under 1 = or > Over-range 2 = ur > Under-range	0	r/w
9	oPE	288	648	Safety output value	-100 ÷ 100 (%)	0	r/w

n.	Para meter	address		Mining	Values	Dec	r/w
		Hex	Dec				
10	diF1	289	649	Digital input 1 function Note: The digital input status is available even if the input is "not used".	0 = oFF > not used 1 = Alarm Reset 2 = Alarm acknowledge (ACK) 3 = Hold of the measured value 4 = Stand by mode 5 = HEAt with SP1 and Cool with "SP2" 6 = Timer run/hold/reset [transition] 7 = Timer run [transition] 8 = Timer reset [transition] 9 = Timer run/hold [Status] 10 = Program run 11 = Program reset 12 = Program hold 13 = Program run/hold 14 = Program run/reset 15 = Instrument in Manual mode 16 = Sequential set point selection 17 = SP1 / SP2 selection 18 = Set point Binary selection 19 = Digital inputs in parallel to the UP and Down keys	0	r/w
11	diF2	28A	650	Digital input 12 function Note: The digital input status is available even if the input is "not used".	0 = oFF > not used 1 = Alarm Reset 2 = Alarm acknowledge (ACK) 3 = Hold of the measured value 4 = Stand by mode 5 = HEAt with SP1 and Cool with "SP2" 6 = Timer run/hold/reset [transition] 7 = Timer run [transition] 8 = Timer reset [transition] 9 = Timer run/hold [Status] 10 = Program run 11 = Program reset 12 = Program hold 13 = Program run/hold 14 = Program run/reset 15 = Instrument in Manual mode 16 = Sequential set point selection 17 = SP1 / SP2 selection 18 = Set point Binary selection 19 = Digital inputs in parallel to the UP and Down keys	0	r/w

out Group

n.	Parameter	Address		Meaning	Values	Dec	r/w
		Hex	Dec				
12	o1F	28B	651	Out 1 function	0 = nonE > Output not used 1 = H.rEG > Heating output 2 = c.rEG > Cooling output 3 = AL > Alalm output 4 = t.out > Timer output 5 = t.HoF > Timer out -OFF in hold 6 = P. End > Program end 7 = P.HLd > Program Hold 8 = P.uit > Program wait 9 = P.run > Program Run 10 = P.Et1 > Program Event 1 11 = P.Et2 > Program Event 2 12 = or.bo > Over-range & burnout 13 = P.FaL > Power failure 14 = bo.PF > Burnout & power Fail 15 = diF1 > The output repeats the digital input 1 status 16 = diF2 > The output repeats the digital input 2 status 17 = St.bY > Instruemnt in stand by mode	0	r/w
13	o1AL	28C	652	Alarms linked up with the out 1	0 ÷ 15 +1 > Alarm 1 +2 > Alarm 2 +4 > Alarm 3 +8 > Loop break alarm	0	r/w
14	o1Ac	28D	653	Out 1 action	0 = dir > Direct 1 = rEV = Reverse 2 = dir.r > Direct with reversed LED 3 = rev.r > reverse with reversed LED	0	r/w
15	o2F	28E	654	Out 2 function	See o1.F	0	r/w
16	o2AL	28F	655	Alarms linked up with the out 2	See o1.AL	0	r/w
17	o2Ac	290	656	Out 2 action	See o1Ac	0	r/w
18	o3F	291	657	Out 3 function	See o1.F	0	r/w
19	o3AL	292	658	Alarms linked up with the out 3	See o1.AL	0	r/w
20	o3Ac	293	659	Out 3 action	See o1Ac	0	r/w
21	o4F	294	660	Out 4 function	See o1.F	0	r/w
22	o4AL	295	661	Alarms linked up with the out 4	See o1.AL	0	r/w
23	o4Ac	296	662	Out 4 action	See o1Ac	0	r/w
24	o5F	297	663	Out 5 function	See o1.F	0	r/w
25	o5AL	298	664	Alarms linked up with the out 5	See o1.AL	0	r/w
26	o5Ac	299	665	Out 5 action	See o1Ac	0	r/w

AL1 Group

n.	Parameter	address		Meaning	Values	Dec	r/w
		Hex	Dec				
27	AL1t	29A	666	Alarm 1 type	0 = nonE. 1 = LoAb > Absolute low alarm 2 = HiAb > Absolute high alarm 3 = LHAb > Absolute band alarm 4 = LodE > Deviation low alarm 5 = HidE > Deviation high alarm 6 = LHdE > Band alarm	0	r/w
28	Ab1	29B	667	Alarm 1 function	0 ÷ 15 +0 = no function +1 = not active at power up +2 = latched alarm +4 = Acknowledgeable alarm +8 = Mask alarm at power up and after a set point change.	0	r/w
29	AL1L	29C	668	- For High and low alarms, it is the low limit of the AL1 threshold - For band alarm, it is low alarm threshold	from -1999 to AL1H (E.U.)	dP	r/w
30	AL1H	29D	669	- For High and low alarms, it is the high limit of the AL1 threshold - For band alarm, it is high alarm threshold	From AL1L to 9999 (E.U.)	dP	r/w
31	AL1	29E	670	Alarm 1 threshold	From AL1L to AL1H (E.U.)	dP	r/w
32	HAL1	29F	671	Alarm 1 hysteresis	From 0 = (oFF) to 9999 (E.U.)	dP	r/w
33	AL1d	2A0	672	Alarm 1 delay	From 0 = (oFF) to 9999 (s)	0	r/w
34	AL1o	2A1	673	Alarm 1 enabling during Stand-by mode	0 = no > Alarm disabled 1 = YES > Alarm enabled	0	r/w

AL2 group

n.	Parameter	Address		Meaning	Values	Dec	r/w
		Hex	Dec				
35	AL2t	2A2	674	Alarm 2 type	0 = nonE. 1 = LoAb > Absolute low alarm 2 = HiAb > Absolute high alarm 3 = LHAb > Absolute band alarm 4 = LodE > Deviation low alarm 5 = HidE > Deviation high alarm 6 = LHdE > Band alarm	0	r/w
36	Ab2	2A3	675	Alarm 2 function	0 ÷ 15 +0 = no function +1 = not active at power up +2 = latched alarm +4 = Acknowledgeable alarm +8 = Mask alarm at power up and after a set point change.	0	r/w
37	AL2L	2A4	676	- For High and low alarms, it is the low limit of the AL1 threshold - For band alarm, it is low alarm threshold	From -1999 to AL2H (E.U.)	dP	r/w
38	AL2H	2A5	677	- For High and low alarms, it is the high limit of the AL1 threshold - For band alarm, it is high alarm threshold	From AL2L to 9999 (E.U.)	dP	r/w

n.	Parameter	Address		Meaning	Values	Dec	r/w
		Hex	Dec				
39	AL2	2A6	678	Alarm 2 threshold	From AL2L to AL2H (E.U.)	dP	r/w
40	HAL2	2A7	679	Alarm 2 hysteresis	From 0 = (oFF) to 9999 (E.U.)	dP	r/w
41	AL2d	2A8	680	Alarm 2 delay	From 0 = (oFF) to 9999 (s)	0	r/w
42	AL2o	2A9	681	Alarm 2 enabling during Stand-by mode	0 = no > Alarm disabled 1 = YES > Alarm enabled	0	r/w

AL3 Group

n.	Parameter	Address		Meaning	Values	Dec	r/w
		Hex	Dec				
43	AL3t	2AA	682	Alarm 3 type	0 = nonE. 1 = LoAb > Absolute low alarm 2 = HiAb > Absolute high alarm 3 = LHAb > Absolute band alarm 4 = LodE > Deviation low alarm 5 = HidE > Deviation high alarm 6 = LHdE > Band alarm	0	r/w
44	Ab3	2AB	683	Alarm 3 function	0 ÷ 15 +0 = no function +1 = not active at power up +2 = latched alarm +4 = Acknowledgeable alarm +8 = Mask alarm at power up and after a set point change.	0	r/w
45	AL3L	2AC	684	- For High and low alarms, it is the low limit of the AL1 threshold - For band alarm, it is low alarm threshold	From -1999 to AL3H (E.U.)	dP	r/w
46	AL3H	2AD	685	- For High and low alarms, it is the high limit of the AL1 threshold - For band alarm, it is high alarm threshold	From AL3L to 9999 (E.U.)	dP	r/w
47	AL3	2AE	686	Alarm 3 threshold	From AL3L to AL3H (E.U.)	dP	r/w
48	HAL3	2AF	687	Alarm 2 hysteresis	From 0 = (oFF) to 9999 (E.U.)	dP	r/w
49	AL3d	2B0	688	Alarm 3 delay	From 0 = (oFF) to 9999 (s)	0	r/w
50	AL3o	2B1	689	Alarm 2 enabling during Stand-by mode	0 = no > Alarm disabled 1 = YES > Alarm enabled	0	r/w

LbA Group

n.	Parameter	address		Meaning	Values	Dec	r/w
		Hex	Dec				
51	LbAt	2B2	690	Loop break alarm time	From 0 = (oFF) to 9999 (s)	0	r/w
52	LbSt	2B3	691	Delta measure used by LBA during Soft start	From 0 = (oFF) to 9999 (E.U.)	dP	r/w
53	LbAS	2B4	692	Delta measure used by LBA	From 0 = (oFF) to 9999 (E.U.)	dP	r/w
54	LbcA	2B5	693	Condition for LBA enabling	0 = uP > active when Pout = 100% 1 = dn > Active when Pout = -100% 2 = both > Active in both cases	0	r/w

rEG Group

n.	Parameter	Address		Meaning	Values	Dec	r/w
		Hex	Dec				
55	cont	2B6	694	Control type When heating and cooling outputs are programmed When heating or cooling outputs are programmed	0 = Pid > PID control 1 = nr > neutral zone On/OFF 0 = Pid > PID control 1 = On.FA > asymmetrical ON/OFF 2 = On.FS > symmetrical ON/OFF	0	r/w
56	Auto	2B7	695	Auto tune selection	-4 = Oscillating auto-tune with automatic restart at power up (after soft start) and after all set point change. -3 = Oscillating auto-tune with manual start. -2 = Oscillating auto-tune with automatic start at the first power up only. -1 = Oscillating auto-tune with automatic restart at every power up 0 = Not used 1 = Fast auto tuning with automatic restart at every power up 2 = Fast auto-tune with automatic start at the first power up only. 3 = FAST auto-tune with manual start 4 = FAST auto-tune with automatic restart at power up (after soft start) and after a set point change.	0	r/w
57	Aut.r	2B8	696	Manual start of the auto-tune Note: it is r/w when a auto-tune with manual start is selected, it is read only in all other cases	0 = oFF > The instrument is NOT performing auto-tune 1 = on > The instrument is performing the auto-tune	0	r/w
58	SELF	2B9	697	Self-tuning enabling	0 = no > self tuning disabled 1 = YES > self tuning enabled	0	r/w
59	HSEt	2BA	698	Hysteresis of the ON/OFF control	From 0 to 9999 (E.U.)	dp	r/w
60	cPdt	2BB	699	Time for compressor protection	From 0 = (oFF) to 9999 (s)	0	r/W
61	Pb	2BC	700	Proportional band	From 1 to 9999 (E.U.)	dp	r/w
62	int	2BD	701	Integral time	From 0 = (oFF) to 10000 = (inF) (s)	0	r/w
63	dEr	2BE	702	Derivative time	From 0 = (oFF) to 9999 (s)	0	r/w
64	Fuoc	2BF	703	Fuzzy overshoot control	From 0 to 200	2	r/w
65	H.Act	2C0	704	Heating output actuator	0 = SSr > SSR 1 = rEly > relay 2 = Slou > slow actuator	0	r/w
66	tcrH	2C1	705	Heating output cycle time	From 0 = (oFF) to 1300 (s)	1	r/w
67	PrAt	2C2	706	Power ratio between heating and cooling action	From 1 to 9999	2	r/w
68	c.Act	2C3	707	Cooling output actuator	0 = SSr > SSR 1 = rELY > relay 2 = SLou > slow actuator	0	
69	tcrC	2C4	708	Cooling output cycle time	From 0 = (oFF) to 1300	1	r/w
70	rS	2C5	709	Manual reset (Integral pre-load)	From -1000 to 1000 (%)	1	r/w

n.	Parameter	Address		Meaning	Values	Dec	r/w
		Hex	Dec				
71	roh.L	2C6	710	Minimum power for heating outputs	From 0 to roh.h (%)	0	r/w
72	roh.H	2C7	711	Maximum power for heating outputs	From roh.L to 100 (%)	0	r/w
73	roc.L	2C8	712	Minimum power for cooling outputs	From 0 to roc.h (%)	0	r/w
74	roc.H	2C9	713	Maximum power for cooling outputs	From roc.L to 100 (%)	0	r/w
75	oPSh	2CA	714	Heating output max rate of rise	From 1 to 51 = (inF) (%/s)	0	r/w
76	oPSC	2CB	715	Cooling output max rate of rise	From 1 to 51 = (inF) (%/s)	0	r/w
77	thrh	2CC	716	Power threshold at which output H.rEG begins to operate.	from -50 to 50 %		
78	thrc	2CD	717	Power threshold at which output C.rEG begins to operate.	from -50 to 50 %		
79	od	2CE	718	Delay at power up	From 0 = (oFF) to 9959 (hh.min)	2	r/w
80	St.P	2CF	719	Maximum power output used during soft start	From -100 to 100 (%)	0	r/w
81	SSt	2D0	720	Soft start time	From 0 = (oFF) to 800 = (inF) (h.min)	2	r/w
82	SSth	2D1	721	Threshold for soft start disabling	From -2000 = (oFF) to 9999 (E.U.)	dP	r/w

SP Group

n.	Parameter	Address		Meaning	Values	Dec	r/w
		Hex	Dec				
83	nSP	2D2	722	Number of used set points	From 1 to 4	0	r/w
84	SPLL	2D3	723	Minimum set point value	From -1999 to SPLH (E.U.)	dP	r/w
85	SPLH	2D4	724	Maximum set point value	From SPLL to 9999 (E.U.)	dP	r/w
86	SP 1	2D5	725	Set point 1	From SPLL to SPLH (E.U.)	dP	r/w
87	SP 2	2D6	726	Set point 2	From SPLL to SPLH (E.U.)	dP	r/w
88	SP 3	2D7	727	Set point 3	From SPLL to SPLH (E.U.)	dP	r/w
89	SP 4	2D8	728	Set point 4	From SPLL to SPLH (E.U.)	dP	r/w
90	SPAt	2D9	729	Active set point selection	0 = SP 1 1 = SP 2 2 = SP 3 3 = SP 4	0	r/w

n.	Parameter	Address		Meaning	Values	Dec	r/w
		Hex	Dec				
91	SP.rt	2DA	730	Remote set point type	0 = rSP > The value coming from serial link is used as remote set point (RSP). 1 = trin > The value coming from serial link will be algebraically added to the local set point selected by SPAt and the sum becomes the operative set point 2 = PErc > The value coming from serial will be scaled on the input range and this value will be used as remote set point	0	r/w
92	SPLr	2DB	731	Local/remote set point selection	0 = Loc > Local 1 = rEn > Remote	0	r/w
93	SP.u	2DC	732	Rate of rise for positive set point change (ramp up)	From 1 to 10000 = (inF) units per minute	2	r/w
94	SP.d	2DD	733	Rate of rise for negative set point change (ramp down)	From 1 to 10000 = (inF) units per minute	2	r/w

tin group

n.	Parameter	address		Meaning	Values	Dec	r/w
		Hex	Dec				
95	tr.F	2DE	734	Independent timer function	0 = nonE > Timer not used 1 = i.d.A > Delayed start timer 2 = i.uP.d > Delayed start at power up 3 = i.d.d > Feed-through timer 4 = i.P.L > Asymmetrical oscillator with start in OFF 5 = i.L.P > Asymmetrical oscillator with start in ON	0	r/w
96	tr.u	2DF	735	Engineering tuning of the time	0 = hh.nn > Hours and minutes 1 = nn.SS > Minutes and seconds 2 = SSS.d > seconds and thenth of seconds	0	r/w
97	tr.t1	2E0	736	Time 1	From 1 to 9959 (hh.min) when tr.u = 0 From 1 to 9959 (mm.ss) when tr.u = 1 From 1 to 9959 (tenth of second) when tr.u = 2	2 1	r/w
98	tr.t2	2E1	737	Time 2	From 0 (oFF) to 9959 (inF) (hh.min) when tr.u = 0 From 0 (oFF) to 9959 (inF) (mm.ss) when tr.u = 1 From 0 (oFF) to 9959 (inF) (tenth of second) when tr.u = 2	2 1	r/w
99	tr.St	2E2	738	Timer status	0 = rES 1 = run 2 = HoLd	0	r/w

PrG Group

n.	Parameter	address		Meaning	Values	Dec	r/w
		Hex	Dec				
100	Pr.F	2E3	739	Programmer action at power up	0 = nonE > Program not used 1 = S.uP.d > Start at power up with a first step in stand by 2 = S.uP.S > Start at power up 3 = u.diG > Start at RUN command detection only 4 = U.dG.d > Start at RUN command detection with a first step in stand by	0	r/w
101	Pr.u	2E4	740	Engineering unit of the time (soak)	0 = hh.nn > hours and minutes 1 = nn.SS > minutes and seconds	0	r/w
102	Pr.E	2E5	741	Instrument behaviour at the End of the program execution	0= cnt > continue (the instrument will use the set point of the last soak until a reset command is detected) 1 = SPAt > go to the set point selected by [79] SPAt parameter 2 = St.bY > Go in stand by mode.	0	r/w
103	Pr.Et	2E6	742	Time of the “end program” indication	From 0 = (oFF) to 10000 = (inF) (mm.ss)	2	r/w
104	Pr.S1	2E7	743	Set point of the first soak	From SPLL to SPHL (E.U.) -8000 = Program END	dP	r/w
105	Pr.G1	2E8	744	Gradient of the first ramp	From 1 to 10000 = (inF) (Unit/min) where inF = step transfer	1	r/w
106	Pr.t1	2E9	745	Time of the first soak	From 0 to 9959	2	r/w
107	Pr.b1	2EA	746	Wait band of the first soak	From 0 = (oFF) to 9999 (E.U.)	0	r/w
108	Pr.E1	2EB	747	Event of the first group	From 00.00 to 11.11 (binary)	2	r/w
109	Pr.S2	2EC	748	Set point of the second soak	From SPLL to SPHL (E.U.) -8000 = Program END	dP	r/w
110	Pr.G2	2ED	749	Gradient of the second ramp	From 1 to 10000 = (inF) (Unit/min) where inF = step transfer	1	r/w
111	Pr.t2	2EE	750	Time of the second soak	From 0 to 9959	2	r/w
112	Pr.b2	2EF	751	Wait band of the second soak	From 0 = (oFF) to 9999 (E.U.)	0	r/w
113	Pr.E2	2F0	752	Event of the second group	From 00.00 to 11.11 (binary)	2	r/w
114	Pr.S3	2F1	753	Set point of the third soak	From SPLL to SPHL (E.U.) -8000 = Program END	dP	r/w
115	Pr.G3	2F2	754	Gradient of the third ramp	From 1 to 10000 = (inF) (Unit/min) where inF = step transfer	1	r/w
116	Pr.t3	2F3	755	Time of the third soak	From 0 to 9959	2	r/w
117	Pr.b3	2F4	756	Wait band of the third soak	From 0 = (oFF) to 9999 (E.U.)	0	r/w
118	Pr.E3	2F5	757	Events of the third group	From 00.00 to 11.11 (binary)	2	r/w
119	Pr.S4	2F6	758	Set point of the fourth soak	From SPLL to SPHL (E.U.) -8000 = Program END	dP	r/w
120	Pr.G4	2F7	759	Gradient of the fourth ramp	From 1 to 10000 = (inF) (Unit/min) where inF = step transfer	1	r/w
121	Pr.t4	2F8	760	Time of the fourth soak	From 0 to 9959	2	r/w
122	Pr.b4	2F9	761	Wait band of the fourth soak	From 0 = (oFF) to 9999 (E.U.)	0	r/w
123	Pr.E4	2FA	762	Events of the fourth group	From 00.00 to 11.11 (binary)	2	r/w

n.	Parameter	address		Meaning	Values	Dec	r/w
		Hex	Dec				
124	Pr.St	2FB	763	Program status	0 = rES 1 = run 2 = HoLd	0	r/w

PAn Group

n.	Parameter	Address		Meaning	Values	Dec	r/w
		Hex	Dec				
125	PAS2	2FC	764	Level 2 password: Assistance	From 0 = (oFF) to 999	0	r/w
126	PAS3	2FD	765	Level 3 password: Configuration	From 0 to 999	0	r/w
127	uSrb	2FE	766	U button function during run time	0 = nonE > No function 1 = tunE > Auto-tune/self-tune enabling. 2 = oPLo > Manual mode. 3 = AAc > Alarm reset 4 = ASi > Alarm acknowledge 5 = chSP > Sequential set point selection 6 = St.by > Stand by mode 7 = Str.t > Timer run/hold/reset 8 = P.run > Program run 9 = P.rES > Program reset. 10 = P.r.H.r > Program run/hold/reset	0	r/w
128	diSP	2FF	767	Display management	0= nonE > Standard display 1 = Pou > Power output 2 = SPF > Final set point 3 = SPo > Operative set point 4 = AL1 > Alarm 1 threshold 5 = AL2 > Alarm 2 threshold 6 = AL3 > Alarm 3 threshold 7 = Pr.tu > Increasing time count of the current soak. 8 = Pr.td > Decreasing time count of the current soak. 9 = P.t.tu > Increasing time count of the total program time. 10 = P.t.td > Decreasing time count of the total program time. 11 = ti.uP > Increasing time of the timer 12 = ti.du > Decreasing time of the timer 13 = Perc > Percent of the power output used during soft start.		r/w
129	AdE	300	768	Bargraph deviation	From 0 = (oFF) to 9999 (E.U.)	Dp	r/w
130	FiLd	301	769	Digital filter on the displayed value	From 0 = (oFF) to 9999	1	r/w
131	DSPu	302	770	Status of the instrument at power up	0 = AS.Pr > Starts in the same way it was prior to the power down. 1 = Auto > Starts in AUTO mode 2 = oP.o > Starts in Manual mode with a power out equal to 0 3= StbY > Starts in stand-by mode	0	r/w
132	oPr.E	303	771	Operative modes enabling	0 = ALL > All 1 = Au.oP > Only Auto and Man. 2 = Au.Sb > Only Auto and Stand-by	0	r/w
133	oPEr	304	772	Operative mode selection	0 = Auto > Auto 1 = oPLo > Manual 2 = StbY > stand by	0	r/w

SEr Group

n.	Parameter	Address		Meaning	Values	Dec	r/w
		Hex	Dec				
134	Add	305	773	Instrument address	From 0 = (oFF) to 254	0	r/w
135	bAud	306	774	Baud rate	0 = 1200 baud 1 = 2400 baud 2 = 9600 baud 3 = 19200 baud 4 = 38400 baud	0	r/w
136	tr.SP	307	775	Remote set point retransmission	0 = not used 1 = Operative Set point 2 = Control output percent	0	r/w

con Group (Wattmeter)

n.	Parameter	Address		Meaning	Values	Dec	r/w
		Hex	Dec				
137	co.tY	308	776	Measurement type	0 = Off- not used 1 = Istantaneous power (KW) 2 = Power consumption (KW/h) 3 = Power consumption during program run. 4 = Worked days 5 = Worked hours	0	r/w
138	UOLt	309	777	Nominal voltage	From 1 to 999 (Volt)	0	r/w
139	cur	30A	778	Nominal current	From 1 to 9999 (A)	0	r/w
140	H.Job	30B	779	Threshold of the worked days/hours	From 0 = (oFF) to 9999	0	r/w

cAL Group

n.	Parameter	Address		Meaning	Values	Dec	r/w
		Hex	Dec				
141	A.L.P	30C	780	Adjust low point	From -1999 to A.H.P-10 (E.U.)	dP	r/w
142	A.L.o	30D	781	Adjust low offset	From -300 to 300 (E.U.)	dP	r/w
143	A.H.P	30E	782	Adjust high point	From A.L.P+10 to 9999 (E.U.)	dP	r/w
144	A.H.o	30F	783	Adjust high offset	From -300 to 300 (E.U.)	dP	r/w

Configuration parameters High address

inP group (Inputs parameters)

n.	Para meter	address		Mining	Values	Dec	r/w
		Hex	Dec				
1	HcFG	2800	10240	Built in Hardware	0 = 0 > TC/RTD 1 = 1 > TC/PTC 2 = 2 > Corrente 3 = 3 > Volt	0	r
2	SEnS	2801	10241	Input type Note: According to the built in hardware Hardware: TC, Pt100 TC, PTC, NTC Current (I) Voltage (V)	0 = J, 1 = crAL, 2 = S, 3 = r, 4 = t, 5 = ir.J, 6 = ir.cA, 7 = Pt1, 8 = 0.50 (mV), 9 = 0.60 (mV), 10 = 12.60 (mV) 0 = J, 1 = crAL, 2 = S, 3 = r, 4 = t, 5 = ir.J, 6 = ir.cA, 7 = Ptc, 8 = ntc, 9 = 0.50 (mV), 10 = 0.60 (mV), 11 = 12.60 (mV) 0 = 0.20 (mA), 1 = 4.20 (mA) 0 = 0.1 (V), 1 = 0.5(V), 2 = 1.5(V), 3 = 0.10(V), 4 = 2.10(V)	0	r/w
3	dP	2802	10242	Decimal figures	0 ÷ 3 for linear inputs 0 ÷ 1 for TC, RTD, PTC, NTC	0	r/w
4	SSc	2803	10243	Initial scale readout for linear inputs	-1999 ÷ FSC (E.U.)	dP	r/w
5	FSc	2804	10244	Full scale readout for linear inputs	SSC ÷ 9999 (E.U.)	dP	r/w
6	unit	2805	10245	Engineering unit.	0 = C > °C 1 = F > °F	0	r/w
7	FiL	2806	10246	Digital input filter Note This filter affect the control, the retrasmission and the alarm actions.	0 = (oFF) ÷ 200	1	r/w
8	inE	2807	10247	Selection of the Sensor Out of Range type that will enable the safety output value	0 = our > Over and Under 1 = or > Over-range 2 = ur > Under-range	0	r/w
9	oPE	2808	10248	Safety output value	-100 ÷ 100 (%)	0	r/w

n.	Para meter	address		Mining	Values	Dec	r/w
		Hex	Dec				
10	diF1	2809	10249	Digital input 1 function Note: The digital input status is available even if the input is "not used".	0 = oFF > not used 1 = Alarm Reset 2 = Alarm acknowledge (ACK) 3 = Hold of the measured value 4 = Stand by mode 5 = HEAt with SP1 and Cool with "SP2" 6 = Timer run/hold/reset [transition] 7 = Timer run [transition] 8 = Timer reset [transition] 9 = Timer run/hold [Status] 10 = Program run 11 = Program reset 12 = Program hold 13 = Program run/hold 14 = Program run/reset 15 = Instrument in Manual mode 16 = Sequential set point selection 17 = SP1 / SP2 selection 18 = Set point Binary selection 19 = Digital inputs in parallel to the UP and Down keys	0	r/w
11	diF2	280A	10250	Digital input 12 function Note: The digital input status is available even if the input is "not used".	0 = oFF > not used 1 = Alarm Reset 2 = Alarm acknowledge (ACK) 3 = Hold of the measured value 4 = Stand by mode 5 = HEAt with SP1 and Cool with "SP2" 6 = Timer run/hold/reset [transition] 7 = Timer run [transition] 8 = Timer reset [transition] 9 = Timer run/hold [Status] 10 = Program run 11 = Program reset 12 = Program hold 13 = Program run/hold 14 = Program run/reset 15 = Instrument in Manual mode 16 = Sequential set point selection 17 = SP1 / SP2 selection 18 = Set point Binary selection 19 = Digital inputs in parallel to the UP and Down keys	0	r/w

out Group

n.	Parameter	Address		Meaning	Values	Dec	r/w
		Hex	Dec				
12	o1F	280B	10251	Out 1 function	0 = nonE > Output not used 1 = H.rEG > Heating output 2 = c.rEG > Cooling output 3 = AL > Alarm output 4 = t.out > Timer output 5 = t.HoF > Timer out -OFF in hold 6 = P. End > Program end 7 = P.HLd > Program Hold 8 = P.uit > Program wait 9 = P.run > Program Run 10 = P.Et1 > Program Event 1 11 = P.Et2 > Program Event 2 12 = or.bo > Over-range & burnout 13 = P.FaL > Power failure 14 = bo.PF > Burnout & power Fail 15 = diF1 > The output repeats the digital input 1 status 16 = diF2 > The output repeats the digital input 2 status 17 = St.bY > Instrument in stand by mode	0	r/w
13	o1AL	280C	10252	Alarms linked up with the out 1	0 ÷ 15 +1 > Alarm 1 +2 > Alarm 2 +4 > Alarm 3 +8 > Loop break alarm	0	r/w
14	o1Ac	280D	10253	Out 1 action	0 = dir > Direct 1 = rEV = Reverse 2 = dir.r > Direct with reversed LED 3 = rev.r > reverse with reversed LED	0	r/w
15	o2F	280E	10254	Out 2 function	See o1.F	0	r/w
16	o2AL	280F	10255	Alarms linked up with the out 2	See o1.AL	0	r/w
17	o2Ac	2810	10256	Out 2 action	See o1Ac	0	r/w
18	o3F	2811	10257	Out 3 function	See o1.F	0	r/w
19	o3AL	2812	10258	Alarms linked up with the out 3	See o1.AL	0	r/w
20	o3Ac	2813	10259	Out 3 action	See o1Ac	0	r/w
21	o4F	2814	10260	Out 4 function	See o1.F	0	r/w
22	o4AL	2815	10261	Alarms linked up with the out 4	See o1.AL	0	r/w
23	o4Ac	2816	10262	Out 4 action	See o1Ac	0	r/w
24	o5F	2817	10263	Out 5 function	See o1.F	0	r/w
25	o5AL	2818	10264	Alarms linked up with the out 5	See o1.AL	0	r/w
26	o5Ac	2819	10265	Out 5 action	See o1Ac	0	r/w

AL1 Group

n.	Parameter	address		Meaning	Values	Dec	r/w
		Hex	Dec				
27	AL1t	281A	10266	Alarm 1 type	0 = nonE. 1 = LoAb > Absolute low alarm 2 = HiAb > Absolute high alarm 3 = LHAb > Absolute band alarm 4 = LodE > Deviation low alarm 5 = HidE > Deviation high alarm 6 = LHdE > Band alarm	0	r/w
28	Ab1	281B	10267	Alarm 1 function	0 ÷ 15 +0 = no function +1 = not active at power up +2 = latched alarm +4 = Acknowledgeable alarm +8 = Mask alarm at power up and after a set point change.	0	r/w
29	AL1L	281C	10268	- For High and low alarms, it is the low limit of the AL1 threshold - For band alarm, it is low alarm threshold	from -1999 to AL1H (E.U.)	dP	r/w
30	AL1H	281D	10269	- For High and low alarms, it is the high limit of the AL1 threshold - For band alarm, it is high alarm threshold	From AL1L to 9999 (E.U.)	dP	r/w
31	AL1	281E	10270	Alarm 1 threshold	From AL1L to AL1H (E.U.)	dP	r/w
32	HAL1	281F	10271	Alarm 1 hysteresis	From 0 = (oFF) to 9999 (E.U.)	dP	r/w
33	AL1d	2820	10272	Alarm 1 delay	From 0 = (oFF) to 9999 (s)	0	r/w
34	AL1o	2821	10273	Alarm 1 enabling during Stand-by mode	0 = no > Alarm disabled 1 = YES > Alarm enabled	0	r/w

AL2 group

n.	Parameter	Address		Meaning	Values	Dec	r/w
		Hex	Dec				
35	AL2t	2822	10274	Alarm 2 type	0 = nonE. 1 = LoAb > Absolute low alarm 2 = HiAb > Absolute high alarm 3 = LHAb > Absolute band alarm 4 = LodE > Deviation low alarm 5 = HidE > Deviation high alarm 6 = LHdE > Band alarm	0	r/w
36	Ab2	2823	10275	Alarm 2 function	0 ÷ 15 +0 = no function +1 = not active at power up +2 = latched alarm +4 = Acknowledgeable alarm +8 = Mask alarm at power up and after a set point change.	0	r/w
37	AL2L	2824	10276	- For High and low alarms, it is the low limit of the AL1 threshold - For band alarm, it is low alarm threshold	From -1999 to AL2H (E.U.)	dP	r/w
38	AL2H	2825	10277	- For High and low alarms, it is the high limit of the AL1 threshold - For band alarm, it is high alarm threshold	From AL2L to 9999 (E.U.)	dP	r/w

n.	Parameter	Address		Meaning	Values	Dec	r/w
		Hex	Dec				
39	AL2	2826	10278	Alarm 2 threshold	From AL2L to AL2H (E.U.)	dP	r/w
40	HAL2	2827	10279	Alarm 2 hysteresis	From 0 = (oFF) to 9999 (E.U.)	dP	r/w
41	AL2d	2828	10280	Alarm 2 delay	From 0 = (oFF) to 9999 (s)	0	r/w
42	AL2o	2829	10281	Alarm 2 enabling during Stand-by mode	0 = no > Alarm disabled 1 = YES > Alarm enabled	0	r/w

AL3 Group

n.	Parameter	Address		Meaning	Values	Dec	r/w
		Hex	Dec				
43	AL3t	282A	10282	Alarm 3 type	0 = nonE. 1 = LoAb > Absolute low alarm 2 = HiAb > Absolute high alarm 3 = LHAb > Absolute band alarm 4 = LodE > Deviation low alarm 5 = HidE > Deviation high alarm 6 = LHdE > Band alarm	0	r/w
44	Ab3	282B	10283	Alarm 3 function	0 ÷ 15 +0 = no function +1 = not active at power up +2 = latched alarm +4 = Acknowledgeable alarm +8 = Mask alarm at power up and after a set point change.	0	r/w
45	AL3L	282C	10284	- For High and low alarms, it is the low limit of the AL1 threshold - For band alarm, it is low alarm threshold	From -1999 to AL3H (E.U.)	dP	r/w
46	AL3H	282D	10285	- For High and low alarms, it is the high limit of the AL1 threshold - For band alarm, it is high alarm threshold	From AL3L to 9999 (E.U.)	dP	r/w
47	AL3	282E	10286	Alarm 3 threshold	From AL3L to AL3H (E.U.)	dP	r/w
48	HAL3	282F	10287	Alarm 2 hysteresis	From 0 = (oFF) to 9999 (E.U.)	dP	r/w
49	AL3d	2830	10288	Alarm 3 delay	From 0 = (oFF) to 9999 (s)	0	r/w
50	AL3o	2831	10289	Alarm 2 enabling during Stand-by mode	0 = no > Alarm disabled 1 = YES > Alarm enabled	0	r/w

LbA Group

n.	Parameter	address		Meaning	Values	Dec	r/w
		Hex	Dec				
51	LbAt	2832	10290	Loop break alarm time	From 0 = (oFF) to 9999 (s)	0	r/w
52	LbSt	2833	10291	Delta measure used by LBA during Soft start	From 0 = (oFF) to 9999 (E.U.)	dP	r/w
53	LbAS	2834	10292	Delta measure used by LBA	From 0 = (oFF) to 9999 (E.U.)	dP	r/w

n.	Parameter	address		Meaning	Values	Dec	r/w
		Hex	Dec				
54	LbcA	2835	10293	Condition for LBA enabling	0 = uP > active when Pout =100% 1 = dn > Active when Pout= -100% 2 = both > Active in both cases	0	r/w

rEG Group

n.	Parameter	Address		Meaning	Values	Dec	r/w
		Hex	Dec				
55	cont	2836	10294	Control type When heating and cooling outputs are programmed When heating or cooling outputs are programmed	0 = Pid > PID control 1 = nr > neutral zone On/OFF 0 = Pid > PID control 1 = On.FA > asymmetrical ON/OFF 2 = On.FS > symmetrical ON/OFF	0	r/w
56	Auto	2837	10295	Auto tune selection	-4 = Oscillating auto-tune with automatic restart at power up (after soft start) and after all set point change. -3 = Oscillating auto-tune with manual start. -2 = Oscillating auto-tune with automatic start at the first power up only. -1 = Oscillating auto-tune with automatic restart at every power up 0 = Not used 1 = Fast auto tuning with automatic restart at every power up 2 = Fast auto-tune with automatic start at the first power up only. 3 = FAST auto-tune with manual start 4 = FAST auto-tune with automatic restart at power up (after soft start) and after a set point change.	0	r/w
57	Aut.r	2838	10296	Manual start of the auto-tune Note: it is r/w when a auto-tune with manual start is selected, it is read only in all other cases	0 = oFF > The instrument is NOT performing auto-tune 1 = on > The instrument is performing the auto-tune	0	r/w
58	SELF	2839	10297	Self-tuning enabling	0 = no > self tuning disabled 1 = YES > self tuning enabled	0	r/w
59	HSEt	283A	10298	Hysteresis of the ON/OFF control	From 0 to 9999 (E.U.)	dp	r/w
60	cPdt	283B	10299	Time for compressor protection	From 0 = (oFF) to 9999 (s)	0	r/W
61	Pb	283C	10300	Proportional band	From 1 to 9999 (E.U.)	dp	r/w
62	int	283D	10301	Integral time	From 0 = (oFF) to 10000 = (inF) (s)	0	r/w
63	dEr	283E	10302	Derivative time	From 0 = (oFF) to 9999 (s)	0	r/w
64	Fuoc	283F	10303	Fuzzy overshoot control	From 0 to 200	2	r/w
65	H.Act	2840	10304	Heating output actuator	0 = SSr > SSR 1 = rEly > relay 2 = Slou > slow actuator	0	r/w
66	tcrH	2841	10305	Heating output cycle time	From 0 = (oFF) to 1300 (s)	1	r/w

n.	Parameter	Address		Meaning	Values	Dec	r/w
		Hex	Dec				
67	PrAt	2842	10306	Power ratio between heating and cooling action	From 1 to 9999	2	r/w
68	c.Act	2843	10307	Cooling output actuator	0 = SSr > SSR 1 = rELY > relay 2 = SLou > slow actuator	0	
69	tcrc	2844	10308	Cooling output cycle time	From 0 = (oFF) to 1300	1	r/w
70	rS	2845	10309	Manual reset (Integral pre-load)	From -1000 to 1000 (%)	1	r/w
71	roh.L	2846	10310	Minimum power for heating outputs	From 0 to roh.h (%)	0	r/w
72	roh.H	2847	10311	Maximum power for heating outputs	From roh.L to 100 (%)	0	r/w
73	roc.L	2848	10312	Minimum power for cooling outputs	From 0 to roc.h (%)	0	r/w
74	roc.H	2849	10313	Maximum power for cooling outputs	From roc.L to 100 (%)	0	r/w
75	oPSh	284A	10314	Heating output max rate of rise	From 1 to 51 = (inF) (%/s)	0	r/w
76	oPSC	284B	10315	Cooling output max rate of rise	From 1 to 51 = (inF) (%/s)	0	r/w
77	thrh	284C	10316	Power threshold at which output H.rEG begins to operate.	from -50 to 50 %		
78	thrc	284D	10317	Power threshold at which output C.rEG begins to operate.	from -50 to 50 %		
79	od	284E	10318	Delay at power up	From 0 = (oFF) to 9959 (hh.min)	2	r/w
80	St.P	284F	10319	Maximum power output used during soft start	From -100 to 100 (%)	0	r/w
81	SSt	2850	10320	Soft start time	From 0 = (oFF) to 800 = (inF) (h.min)	2	r/w
82	SSth	2851	10321	Threshold for soft start disabling	From -2000 = (oFF) to 9999 (E.U.)	dP	r/w

SP Group

n.	Parameter	Address		Meaning	Values	Dec	r/w
		Hex	Dec				
83	nSP	2852	10322	Number of used set points	From 1 to 4	0	r/w
84	SPLL	2853	10323	Minimum set point value	From -1999 to SPLH (E.U.)	dP	r/w
85	SPLH	2854	10324	Maximum set point value	From SPLL to 9999 (E.U.)	dP	r/w
86	SP 1	2855	10325	Set point 1	From SPLL to SPLH (E.U.)	dP	r/w
87	SP 2	2856	10326	Set point 2	From SPLL to SPLH (E.U.)	dP	r/w
88	SP 3	2857	10327	Set point 3	From SPLL to SPLH (E.U.)	dP	r/w
89	SP 4	2858	10328	Set point 4	From SPLL to SPLH (E.U.)	dP	r/w
90	SPAt	2859	10329	Active set point selection	0 = SP 1 1 = SP 2 2 = SP 3 3 = SP 4	0	r/w

n.	Parameter	Address		Meaning	Values	Dec	r/w
		Hex	Dec				
91	SP.rt	285A	10330	Remote set point type	0 = rSP > The value coming from serial link is used as remote set point (RSP). 1 = trin > The value coming from serial link will be algebraically added to the local set point selected by SPAt and the sum becomes the operative set point 2 = PErc > The value coming from serial will be scaled on the input range and this value will be used as remote set point	0	r/w
92	SPLr	285B	10331	Local/remote set point selection	0 = Loc > Local 1 = rEn > Remote	0	r/w
93	SP.u	285C	10332	Rate of rise for positive set point change (ramp up)	From 1 to 10000 = (inF) units per minute	2	r/w
94	SP.d	285D	10333	Rate of rise for negative set point change (ramp down)	From 1 to 10000 = (inF) units per minute	2	r/w

tin group

n.	Parameter	address		Meaning	Values	Dec	r/w
		Hex	Dec				
95	tr.F	285E	10334	Independent timer function	0 = nonE > Timer not used 1 = i.d.A > Delayed start timer 2 = i.uP.d > Delayed start at power up 3 = i.d.d > Feed-through timer 4 = i.P.L > Asymmetrical oscillator with start in OFF 5 = i.L.P > Asymmetrical oscillator with start in ON	0	r/w
96	tr.u	285F	10335	Engineering tuning of the time	0 = hh.nn > Hours and minutes 1 = nn.SS > Minutes and seconds 2 = SSS.d > seconds and thenth of seconds	0	r/w
97	tr.t1	2860	10336	Time 1	From 1 to 9959 (hh.min) when tr.u = 0 From 1 to 9959 (mm.ss) when tr.u = 1 From 1 to 9959 (tenth of second) when tr.u = 2	2 1	r/w
98	tr.t2	2861	10337	Time 2	From 0 (oFF) to 9959 (inF) (hh.min) when tr.u = 0 From 0 (oFF) to 9959 (inF) (mm.ss) when tr.u = 1 From 0 (oFF) to 9959 (inF) (tenth of second) when tr.u = 2	2 1	r/w
99	tr.St	2862	10338	Timer status	0 = rES 1 = run 2 = HoLd	0	r/w

PrG Group

n.	Parameter	address		Meaning	Values	Dec	r/w
		Hex	Dec				
100	Pr.F	2863	10339	Programmer action at power up	0 = nonE > Program not used 1 = S.uP.d > Start at power up with a first step in stand by 2 = S.uP.S > Start at power up 3 = u.diG > Start at RUN command detection only 4 = U.dG.d > Start at RUN command detection with a first step in stand by	0	r/w
101	Pr.u	2864	10340	Engineering unit of the time (soak)	0 = hh.nn > hours and minutes 1 = nn.SS > minutes and seconds	0	r/w
102	Pr.E	2865	10341	Instrument behaviour at the End of the program execution	0= cnt > continue (the instrument will use the set point of the last soak until a reset command is detected) 1 = SPAt > go to the set point selected by [79] SPAt parameter 2 = St.bY > Go in stand by mode.	0	r/w
103	Pr.Et	2866	10342	Time of the “end program” indication	From 0 = (oFF) to 10000 = (inF) (mm.ss)	2	r/w
104	Pr.S1	2867	10343	Set point of the first soak	From SPLL to SPHL (E.U.) -8000 = Program END	dP	r/w
105	Pr.G1	2868	10344	Gradient of the first ramp	From 1 to 10000 = (inF) (Unit/min) where inF = step transfer	1	r/w
106	Pr.t1	2869	10345	Time of the first soak	From 0 to 9959	2	r/w
107	Pr.b1	286A	10346	Wait band of the first soak	From 0 = (oFF) to 9999 (E.U.)	0	r/w
108	Pr.E1	286B	10347	Event of the first group	From 00.00 to 11.11 (binary)	2	r/w
109	Pr.S2	286C	10348	Set point of the second soak	From SPLL to SPHL (E.U.) -8000 = Program END	dP	r/w
110	Pr.G2	286D	10349	Gradient of the second ramp	From 1 to 10000 = (inF) (Unit/min) where inF = step transfer	1	r/w
111	Pr.t2	286E	10350	Time of the second soak	From 0 to 9959	2	r/w
112	Pr.b2	286F	10351	Wait band of the second soak	From 0 = (oFF) to 9999 (E.U.)	0	r/w
113	Pr.E2	2870	10352	Event of the second group	From 00.00 to 11.11 (binary)	2	r/w
114	Pr.S3	2871	10353	Set point of the third soak	From SPLL to SPHL (E.U.) -8000 = Program END	dP	r/w
115	Pr.G3	2872	10354	Gradient of the third ramp	From 1 to 10000 = (inF) (Unit/min) where inF = step transfer	1	r/w
116	Pr.t3	2873	10355	Time of the third soak	From 0 to 9959	2	r/w
117	Pr.b3	2874	10356	Wait band of the third soak	From 0 = (oFF) to 9999 (E.U.)	0	r/w
118	Pr.E3	2875	10357	Events of the third group	From 00.00 to 11.11 (binary)	2	r/w
119	Pr.S4	2876	10358	Set point of the fourth soak	From SPLL to SPHL (E.U.) -8000 = Program END	dP	r/w
120	Pr.G4	2877	10359	Gradient of the fourth ramp	From 1 to 10000 = (inF) (Unit/min) where inF = step transfer	1	r/w
121	Pr.t4	2878	10360	Time of the fourth soak	From 0 to 9959	2	r/w
122	Pr.b4	2879	10361	Wait band of the fourth soak	From 0 = (oFF) to 9999 (E.U.)	0	r/w
123	Pr.E4	287A	10362	Events of the fourth group	From 00.00 to 11.11 (binary)	2	r/w

n.	Parameter	address		Meaning	Values	Dec	r/w
		Hex	Dec				
124	Pr.St	287B	10363	Program status	0 = rES 1 = run 2 = HoLd	0	r/w

PAn Group

n.	Parameter	Address		Meaning	Values	Dec	r/w
		Hex	Dec				
125	PAS2	287C	10364	Level 2 password: Assistance	From 0 = (oFF) to 999	0	r/w
126	PAS3	287D	10365	Level 3 password: Configuration	From 0 to 999	0	r/w
127	uSrb	287E	10366	U button function during run time	0 = nonE > No function 1 = tunE > Auto-tune/self-tune enabling. 2 = oPLo > Manual mode. 3 = AAc > Alarm reset 4 = ASi > Alarm acknowledge 5 = chSP > Sequential set point selection 6 = St.by > Stand by mode 7 = Str.t > Timer run/hold/reset 8 = P.run > Program run 9 = P.rES > Program reset. 10 = P.r.H.r > Program run/hold/reset	0	r/w
128	diSP	287F	10367	Display management	0= nonE > Standard display 1 = Pou > Power output 2 = SPF > Final set point 3 = SPo > Operative set point 4 = AL1 > Alarm 1 threshold 5 = AL2 > Alarm 2 threshold 6 = AL3 > Alarm 3 threshold 7 = Pr.tu > Increasing time count of the current soak. 8 = Pr.td > Decreasing time count of the current soak. 9 = P.t.tu > Increasing time count of the total program time. 10 = P.t.td > Decreasing time count of the total program time. 11 = ti.uP > Increasing time of the timer 12 = ti.du > Decreasing time of the timer 13 = Perc > Percent of the power output used during soft start.		r/w
129	AdE	2880	10368	Bargraph deviation	From 0 = (oFF) to 9999 (E.U.)	Dp	r/w
130	FiLd	2881	10369	Digital filter on the displayed value	From 0 = (oFF) to 9999	1	r/w
131	DSPu	2882	10370	Status of the instrument at power up	0 = AS.Pr > Starts in the same way it was prior to the power down. 1 = Auto > Starts in AUTO mode 2 = oP.o > Starts in Manual mode with a power out equal to 0 3= StbY > Starts in stand-by mode	0	r/w
132	oPr.E	2883	10371	Operative modes enabling	0 = ALL > All 1 = Au.oP > Only Auto and Man. 2 = Au.Sb > Only Auto and Stand-by	0	r/w
133	oPEr	2884	10372	Operative mode selection	0 = Auto > Auto 1 = oPLo > Manual 2 = StbY > stand by	0	r/w

SER Group

n.	Parameter	Address		Meaning	Values	Dec	r/w
		Hex	Dec				
134	Add	2885	10373	Instrument address	From 0 = (oFF) to 254	0	r/w
135	bAud	2886	10374	Baud rate	0 = 1200 baud 1 = 2400 baud 2 = 9600 baud 3 = 19200 baud 4 = 38400 baud	0	r/w
136	tr.SP	2887	10375	Remote set point retransmission	0 = not used 1 = Operative Set point 2 = Control output percent	0	r/w

con Group (Wattmeter)

n.	Parameter	Address		Meaning	Values	Dec	r/w
		Hex	Dec				
137	co.tY	2888	10376	Measurement type	0 = Off- not used 1 = Istantaneous power (KW) 2 = Power consumption (KW/h) 3 = Power consumption during program run. 4 = Worked days 5 = Worked hours	0	r/w
138	UOLt	2889	10377	Nominal voltage	From 1 to 999 (Volt)	0	r/w
139	cur	288A	10378	Nominal current	From 1 to 9999 (A)	0	r/w
140	H.Job	288B	10379	Threshold of the worked days/hours	From 0 = (oFF) to 9999	0	r/w

cAL Group

n.	Parameter	Address		Meaning	Values	Dec	r/w
		Hex	Dec				
141	A.L.P	288C	10380	Adjust low point	From -1999 to A.H.P-10 (E.U.)	dP	r/w
142	A.L.o	288D	10381	Adjust low offset	From -300 to 300 (E.U.)	dP	r/w
143	A.H.P	288E	10382	Adjust high point	From A.L.P+10 to 9999 (E.U.)	dP	r/w
144	A.H.o	288F	10383	Adjust high offset	From -300 to 300 (E.U.)	dP	r/w

5.1 Identification code zone

This zone provides only informations for identifying model, order code and software release of the K series instrument.

Starting from the address 0800H it's possibile to read the instrument name (TLK41, etc) and from the address 0x80A (up to 0x818) it's possibile to read the instrument sales code (starting from 2.2 version)

6 Performance

After receiving a valid request the instrument prepares the reply, then sends it back to the master station according following specifications:

- a minimum time is granted greater or equal 3 characters time (depending on adopted baud rate, allowing line direction reversal)
- the reply is ready to be transmitted in less then 20 ms except in case 3;

A 20 ms silence on the line is necessary to recover from abnormal contitions or erroneous messages; this means that a time less than 20 ms is allowed between any two characters in the same message.

NOTE VERY WELL: It's now possible to write up to 16 words at the same time.



Tecnologic S.p.A.
Via Indipendenza, 56
27029 Vigevano (PV) Italia

Tel. ++39/0381/69871
Fax ++39/0381/698730
e-mail : support@tecnologic.it
info@tecnologic.it

All rights reserved. No parts of this publication may be reproduced, in any form, without Tecnologic S.p.A. written permission.

Every care has been taken preparing this manual; the document has been carefully reviewed for technical accuracy. In the event that technical or typographical errors exist Tecnologic S.p.A. reserves the right to make changes without any notice.

In no event shall Tecnologic S.p.A. be liable for any damages arising out of or related to this document or the information contained in it.

If errors are suspected, please contact Tecnologic S.p.A. at the above address.