

TLK 96 S

MICROPROCESSOR-BASED DIGITAL ELECTRONIC CONTROLLER



OPERATING INSTRUCTIONS

Vr. 01 (ENG) - 09/05 - cod.: ISTR 06874

TECNOLOGIC S.p.A.

VIA INDIPENDENZA 56
27029 VIGEVANO (PV) ITALY

TEL.: +39 0381 69871

FAX: +39 0381 698730

internet : <http://www.tecnologic.it>

e-mail: info@tecnologic.it

FOREWORD



This manual contains the information necessary for the product to be installed correctly and also instructions for its maintenance and use; we therefore recommend that the utmost attention is paid to the following instructions and to save it.

This document is the exclusive property of TECNOLOGIC S.p.A. which forbids any reproduction and divulgation, even in part, of the document, unless expressly authorized.

TECNOLOGIC S.p.A. reserves the right to make any formal or functional changes at any moment and without any notice.

Whenever a failure or a malfunction of the device may cause dangerous situations for persons, things or animals, please remember that the plant has to be equipped with additional devices which will guarantee safety.

Tecnologic S.p.A. and its legal representatives do not assume any responsibility for any damage to people, things or animals deriving from violation, wrong or improper use or in any case not in compliance with the instrument's features.

INDEX

- 1 INSTRUMENT DESCRIPTION
 - 1.1 GENERAL DESCRIPTION
 - 1.2 FRONT PANEL DESCRIPTION
- 2 PROGRAMMING
 - 2.1 FAST PROGRAMMING OF SET POINTS
 - 2.2 PARAMETER PROGRAMMING
 - 2.3 PARAMETER PROTECTION USING THE PASSWORD AND PARAMETER PROGRAMMING LEVELS
- 3 INFORMATION ON INSTALLATION AND USE
 - 3.1 PERMITTED USE
 - 3.2 MECHANICAL MOUNTING
 - 3.3 ELECTRICAL CONNECTIONS
 - 3.4 ELECTRICAL WIRING DIAGRAM
- 4 FUNCTIONS
 - 4.1 MEASURING AND VISUALIZATION
 - 4.2 ON/OFF CONTROL
 - 4.3 NEUTRAL ZONE ON/OFF CONTROL
 - 4.4 PID CONTROL
 - 4.5 AUTOTUNING FUNCTION
 - 4.6 REACHING OF "SP1" SET POINT AT CONTROLLED SPEED (RAMP)
 - 4.7 DELAY OUTPUTS FUNCTIONS
- 5 PROGRAMMABLE PARAMETERS TABLE
- 6 PROBLEMS, MAINTENANCE AND GUARANTEE
 - 6.1 ERROR SIGNALLING
 - 6.2 CLEANING
 - 6.3 GUARANTEE AND REPAIRS
- 7 TECHNICAL DATA
 - 7.1 ELECTRICAL DATA
 - 7.2 MECHANICAL DATA
 - 7.3 MECHANICAL DIMENSIONS, PANEL CUT-OUT AND MOUNTING
 - 7.4 FUNCTIONAL DATA
 - 7.5 MEASUREMENT RANGE TABLE
 - 7.6 INSTRUMENT ORDERING CODE

1 - INSTRUMENT DESCRIPTION

1.1 - GENERAL DESCRIPTION

TLK 96 S is a digital microprocessor-based controller with ON/OFF, Neutral Zone ON/OFF, PID control and with **AUTO-TUNING** function for PID control.

The process value is visualized on 4 red displays, while the output status is indicated by 2 LED displays. The instrument is equipped with a 3 LED programmable shift indexes and can have up to 2 outputs: relay type or can drive solid state relays type (SSR).

Depending on the model required the input accept:

C: Thermocouples temperature probes (J,K,S and TECNOLOGIC IRS Infrared sensors), mV signals (0..50/60 mV, 12..60 mV), Thermoresistances PT100.

E: Thermocouples temperature probes (J,K,S and TECNOLOGIC IRS Infrared sensors), mV signals (0..50/60 mV, 12..60 mV), Thermistors PTC and NTC.

I: normalized analogue signals 0/4..20 mA

V: normalized analogue signals 0..1 V, 0/1..5 V, 0/2..10 V

1.2 - FRONT PANEL DESCRIPTION

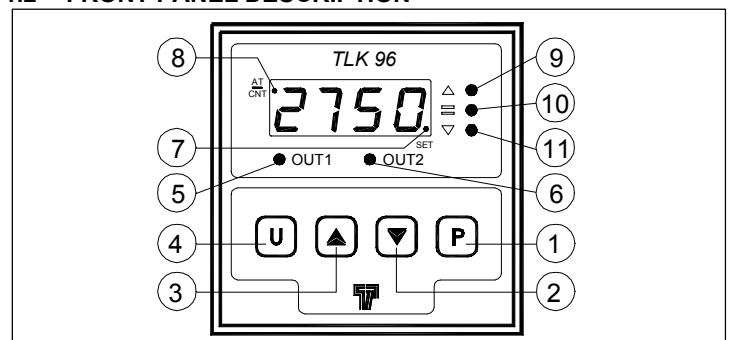

1 - Key P: Used to access function programming parameters and to confirm selection.

2 - Key DOWN : This is used to decrease the values to be set and to select the parameters. If the key is held down while programming parameters, the user exits the programming mode.

3 - Key UP : This is used to increase the values to be set and to select the parameters. If the key is held down, the user while programming parameters the user exits the programming mode.

4 - Key U : This can be used to activate Autotuning (see par. 4.5). When in programming mode, accessed by a password, it can be used to change the parameter programming level (see par. 2.3).

5 - Led OUT1 : indicates the state of output OUT1

6 - Led OUT2 : indicates the state of output OUT2

7 - Led SET : This shows the entry into quick setting mode and the parameter programming level in programming mode.

8 - Led v Shift index: indicates that the process value is lower than [SP1-AdE].

9 - Led = Shift index: indicates that the process value is within the range [SP1+AdE ... SP1-AdE]

10 - Led ^ Shift index: indicates that the process value is higher than [SP1+AdE].

2 - PROGRAMMAZIONE

2.1 - FAST PROGRAMMING OF SET POINTS

Press the key P then release it and the display will show "SP 1" alternating with the set value.

To change it, press the UP key to increase the value or the DOWN key to decrease it.

These keys increase the value by one digit but if pressed down for more than one second, the value increase or decreases rapidly and after two seconds in the same condition, the speed increases further to all the value desired to be set quickly.

The Set point "SP1" can be set at a value between the value set in par. "SP1L" and the value set in par. "SP1H".

If only Set Point 1 has been programmed, the unit will exit rapid setting mode by pressing the key P once the desired value has been set.

If Set Point 2 can also be set by pressing and releasing key P again, the display will show "SP 2" alternating with the set value.

To change it press the keys UP and DOWN.

The Set point "SP2" can be set with a value included between the value set in par. "SP2L" and the value set in par. "SP2H".

Once the desired value has been set, the unit will exit rapid setting mode by pressing the key P.

Pressing the key P allows the user to exit rapid setting mode, after visualising the last Set or automatically if no key is pressed for 15 seconds, after which time the display returns to the normal function mode.

2.2 - PARAMETERS PROGRAMMING

To access the function parameters it is necessary to press key P and keep it pressed for about 3 seconds, after which time the led SET will light up, the display will show the code that identifies the first parameter and using the UP and DOWN keys it will be possible to select the parameter that the user wishes to change.

Once the desired parameter has been selected by pressing the key P, the display will show the parameter code and its setting, alternately. The setting can be changed by using the UP or DOWN keys.

Once the value has been set as desired, press key P again. The new value will be memorized and the display will show the abbreviation of the parameter only once more.

By pressing the UP and DOWN keys, it is possible to select another parameter and to change it as described below.

By pressing the UP and DOWN keys, it is therefore possible to select another parameter and change it as described

To exit the programming mode, do not press any key for about 30 seconds, or keep the UP or DOWN key pressed until it exits the programming mode.

2.3 - PARAMETER PROTECTION USING THE PASSWORD AND PARAMETER PROGRAMMING LEVELS

The instrument has a parameter protection function using a password that can be personalized by using the par. "PASS".

If the user wishes to use this protection, he must set the password number chosen in the parameter "PASS" and exit the parameter-programming mode.

When the protection is active, in order to access the parameters press the key P and keep it pressed for about 3 seconds, after which the led SET will flash the display will show the parameter "r.PAS" and pressing the key P again, the display will show "0".

At this point, set the programmed password number using the keys UP and DOWN and press key P.

If the password is correct, the display will show the code that identifies the first parameter and it will be possible to set the instrument's parameters in the same way described in the previous paragraph.

The protection using passwords can be disabled by setting the par. "PASS" = OFF.

The manufacturer's settings cause the password to protect all parameters.

If the user desires after enabling the password using the "PASS", it is possible to make some parameters programmable without the password by using the following procedure.

Access programming using the password and select the parameter you wish to make programmable without password.

Once the parameter has been selected, if the led SET is turned off, it means that the parameter can be programmed using the password only (therefore it is protected) if instead it is lit up it means that the parameter can be programmed without the password too (not protected).

To change the parameter visibility, press the key U and keep it pressed for about 1 sec. The led SET will change status showing the new accessibility level of the parameter (turned on =not protected; turned off = protected by a password).

If the password is enabled and if some parameters have their protection removed, all the non-protected parameters will be shown when programming is accessed and the par. "r.PAS" will be shown which will allow the user to access the protected parameters.

NOTE: If the password is lost, remove the instrument's power supply, press key P and reinsert power, keeping the key pressed for about 5 seconds.

All parameters will be accessed in this way and it will therefore be possible to check and change the parameter "PASS".

3 - INFORMATION ON INSTALLATION AND USE



3.1 - PERMITTED USE

The instrument has been projected and manufactured as a measuring and control device to be used according to EN61010-1 for the altitudes operation until 2000 ms.

The use of the instrument for applications not expressly permitted by the above mentioned rule must adopt all the necessary protective measures.

The instrument CANNOT be used in dangerous environments (flammable or explosive) without adequate protection.

The installer must ensure that EMC rules are respected, also after the instrument installation, if necessary using proper filters.

Whenever a failure or a malfunction of the device may cause dangerous situations for persons, thing or animals, please remember that the plant has to be equipped with additional devices which will guarantee safety.

3.2 - MECHANICAL MOUNTING

The instrument, in DIN case 96 x 96 mm, is designed for flush-in panel mounting.

Make a hole 90 x 90 mm and insert the instrument, fixing it with the provided special brackets.

We recommend that the gasket is mounted in order to obtain the front protection degree as declared. Avoid placing the instrument in environments with very high humidity levels or dirt that may create condensation or introduction of conductive substances into the instrument.

Ensure adequate ventilation to the instrument and avoid installation in containers that house devices which may overheat or which may cause the instrument to function at a higher temperature than the one permitted and declared.

Connect the instrument as far away as possible from sources of electromagnetic disturbances such as motors, power relays, relays, solenoid valves, etc.

3.3 - ELECTRICAL CONNECTION

Carry out the electrical wiring by connecting only one wire to each terminal, according to the following diagram, checking that the power supply is the same as that indicated on the instrument and that the load current absorption is no higher than the maximum electricity current permitted.

As the instrument is built-in equipment with permanent connection inside housing, it is not equipped with either switches or internal devices to protect against overload of current: the installation will include an overload protection and a two-phase circuit-breaker, placed as near as possible to the instrument, and located in a position that can easily be reached by the user and marked as instrument disconnecting device which interrupts the power supply to the equipment.

It is also recommended that the supply of all the electrical circuits connected to the instrument must be protect properly, using devices (ex. fuses) proportionate to the circulating currents.

It is strongly recommended that cables with proper insulation, according to the working voltages and temperatures, be used.

Furthermore, the input cable of the probe has to be kept separate from line voltage wiring. If the input cable of the probe is screened, it has to be connected to the ground with only one side.

We recommend that a check should be made that the parameters are those desired and that the application functions correctly before connecting the outputs to the actuators so as to avoid malfunctioning that may cause irregularities in the plant that could cause damage to people, things or animals.

3.4 - ELECTRICAL WIRING DIAGRAM

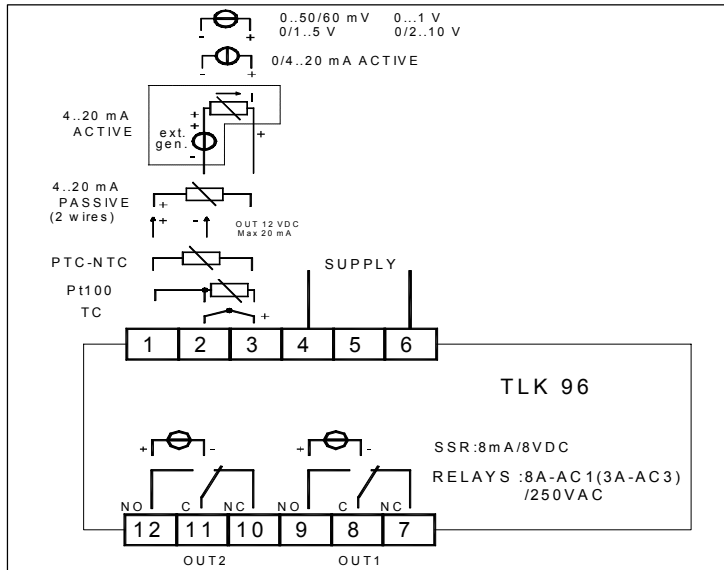

4 - FUNCTIONS

4.1 - MEASURING AND VISUALIZATION

Depending on the model required the input accept:

C: Thermocouples temperature probes (J,K,S and TECHNOLOGIC IRS Infrared sensors), mV signals (0..50/60 mV, 12..60 mV), Thermoresistances PT100.

E: Thermocouples temperature probes (J,K,S and TECHNOLOGIC IRS Infrared sensors), mV signals (0..50/60 mV, 12..60 mV), Thermistors PTC and NTC.

I: normalized analogue signals 0/4..20 mA

V: normalized analogue signals 0..1 V, 0/1..5 V, 0/2..10 V

Depending on the model, using par. "SEnS", it's possible to select the type of input probe, which can be :

- for thermocouples J (J), K (CrAl), S (S) or for infrared sensors serie TECHNOLOGIC IRTC1 with linearization J (Ir.J) or K (Ir.CA)
- for thermoresistances Pt100 IEC (Pt1) or thermistors PTC KTY81-121 (Ptc) or NTC 103AT-2 (ntc)

- for normalised signals in current 0..20 mA (0.20) or 4..20 mA (4.20)

- for normalised signals in tension 0..1 V (0.1), 0..5 V (0.5), 1..5 V (1.5), 0..10 V (0.10) or 2..10 V (2.10).

- for normalised signals in tension 0..50 mV (0.50), 0..60 mV (0.60), 12..60 mV (12.60).

We recommend to switch on and off the instrument when these parameters are modified, in order to obtain a correct measuring.

For the instruments with input for temperature probes (tc, rtd) it's possible to select, through par. "Unit", the unit of measurement (°C, °F) and, through par. "dP" (Pt100, PTC and NTC only) the desired resolution (0=1°; 1=0,1°).

Instead, with regards to the instruments with normalised analogue input signals, it is first necessary to program the desired resolution on par. "dP" (0=1; 1=0,1; 2=0,01; 3=0,001) and then, on par. "SSC", the value that the instrument must visualise at the beginning of the scale (0/4 mA, 0/12 mV, 0/1 V o 0/2 V) and, on par. "FSC", the value that the instrument must visualise at the end of the scale (20 mA, 50 mV, 60 mV, 5 V or 10 V).

The instrument allows for measuring calibration, which may be used to recalibrate the instrument according to application needs, by using par. "OFSt" and "rot".

Programming par. "rot"=1,000, in par. "OFSt" it is possible to set a positive or negative offset that is simply added to the value read by the probe before visualisation, which remains constant for all the measurements.

If instead, it is desired that the offset set should not be constant for all the measurements, it is possible to operate the calibration on any two points.

In this case, in order to decide which values to program on par. "OFSt" and "rot", the following formulae must be applied :

$$\text{"rot"} = (D2-D1) / (M2-M1) \quad \text{"OFSt"} = D2 - (\text{"rot"} \times M2)$$

where:

M1 = measured value 1

D1 = visualisation value when the instrument measures M1

M2 = measured value 2

D2 = visualisation value when the instrument measures M2

It then follows that the instrument will visualise :

$$DV = MV \times \text{"rot"} + \text{"OFSt"}$$

where: DV = visualised value MV= measured value

Example 1: It is desired that the instrument visualises the value effectively measured at 20° but that, at 200°, it visualises a value lower than 10° (190°).

Therefore : M1=20 ; D1=20 ; M2=200 ; D2=190

"rot" = (190 - 20) / (200 - 20) = 0,944

"OFSt" = 190 - (0,944 x 200) = 1,2

Example 2: It is desired that the instrument visualises 10° whilst the value actually measured is 0°, but, at 500° it visualises a 50° higher value (550°).

Therefore : M1=0 ; D1=10 ; M2=500 ; D2=550

"rot" = (550 - 10) / (500 - 0) = 1,08

"OFSt" = 550 - (1,08 x 500) = 10

By using par. "FIL" it is possible to program time constant of the software filter for the input value measured, in order to reduce noise sensitivity (increasing the time of reading).

If a measurement error is made, it is possible to make the outputs OUT1 and OUT2 continue to work in cycles, following the times set in the par. "ton1" - "ton2" (activation times) and "toF1" - "toF2" (deactivation times).

If there is a probe error, the instrument activates the output for the "ton" time and therefore deactivates it for the "toF" time and so on as long as the error continues.

By programming "ton" = OFF the output exit in probe error status will remain turned off.

By programming "ton" to any value and "toF" = OFF the output in probe error status will remain turned on.

By using par. "AdE" it is possible to program the 3 led shift index functioning.

The lighting up of the green led = indicates that the process value is within the range [SP+AdE ... SP-AdE], the lighting up of the led ^ indicates that the process value is lower than [SP-AdE] and the lighting up of the led v indicates that the process value is higher than [SP+AdE].

4.2 - REGOLATORE ON/OFF

This regulation mode can be started by setting the parameter "Cont" = On.FA. and acts on the outputs OUT1 and OUT2 depending on the measurement, of the set points "SP1" and "SP2", of the function mode "Fun1" and "Fun2", and of the hystereses "HSE1" and "HSE2" programmed.

The instrument starts up a ON/OFF regulation with asymmetric hysteresis.

The regulators acts in the following way if they are inverted or if heated ("Fun"=HEAt), they deactivate the output when the process value reaches the value [SP]. To reactivate it when it goes below the value [SP - HSE].

Vice versa, in the event of direct action or cooling ("Fun"=Cool), they deactivate the output when the process value reaches the value [SP], to reactivate it when it rises above the value [SP + HSE].

The Set "SP2" can also be set as independent or dependent from the set "SP1", through the parameter "SP2C".

If "SP2" is set as dependent ("SP2C" = di) the actual regulation setting of the output 2 will be [SP1+SP2].

The functioning of the outputs working in ON/OFF mode can be affected by delay functions that can be set on parameters "Ptd" and "Pts" described below.

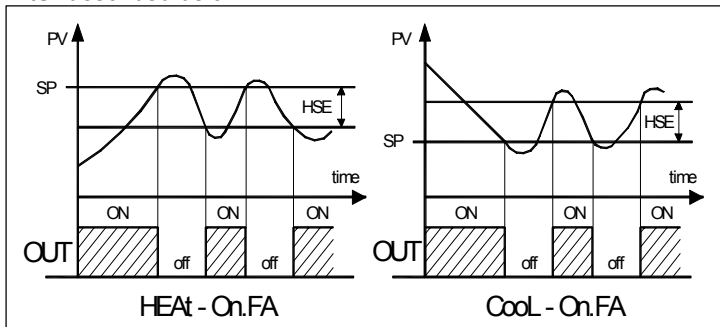

4.3 - NEUTRAL ZONE ON/OFF CONTROL

The neutral zone function is used to control systems that have an element that causes positive increases (e.g. heating, humidifying etc) and an element that causes a negative increase (e.g. cooling, dehumidifying etc.).

This function can be activated when there are 2 outputs and it can be obtained by programming the par. "Cont" = nr.

Using this programming, the instrument excludes the parameters "SP2", "Fun1" and "Fun2" from the function.

The regulation function acts on the outputs depending on the measurement, of the Set point "SP1", and the hystereses "HSE1" and "HSE2" that have been programmed.

The regulator acts in the following way: it turns off the outputs when the process value reaches Set SP1 and activates the output OUT1 when the process value is less than [SP1-HSE1], or it turns on output OUT2 when the process value is greater than [SP1+HSE2].

Consequently the element that causes the positive increase is connected to output OUT1 while the negative increase element is connected to output OUT2.

The functioning of the outputs working in neutral zone mode can be affected by delay functions that can be set on parameters "Ptd" and "Pts" described below.

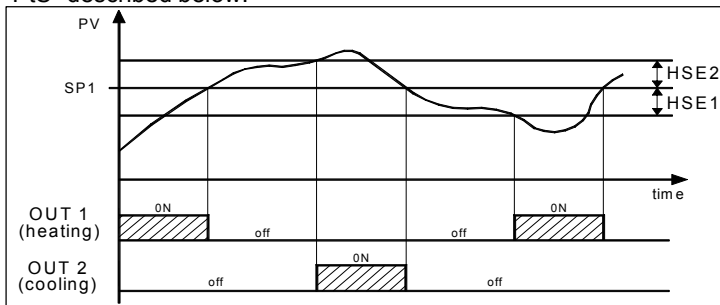

4.4 - PID CONTROL

The Single Action PID control can be obtained by programming par. "Cont" = Pid and works on the output OUT1 depending on the

active Set Point "SP1", on the functioning mode "Fun1" and on the instrument's PID algorithm with two degree of freedom. In this mode, the output OUT2 works in ON/OFF mode.

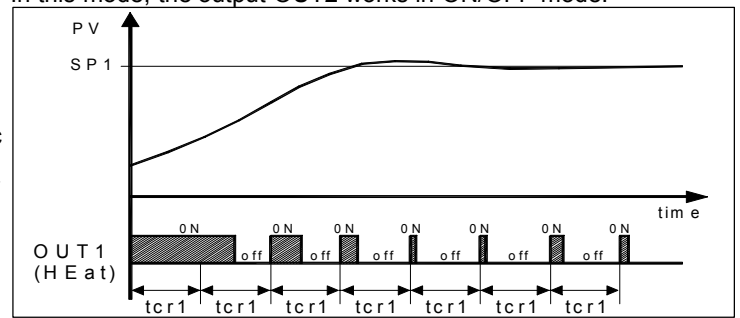

In order to obtain good stability of the process variable, in the event of fast processes, the cycle time "tcr1" has to have a low value with a very frequent intervention of the control output.

In this case use of a solid state relay (SSR) is recommended for driving the actuator.

The Single Action PID control algorithm foresees the setting of the following parameters :

"Pb" – Proportional Band

"tcr1" – Cycle time of the output

"Int" – Integral Time

"rS" – Manual Reset (if "Int = 0 only)

"dEr" – Derivative Time

"FuOC" - Fuzzy Overshoot Control

This last parameter allows the variable overshoots at the start up of the process or at the changing of the Set Point to be avoided.

Please remember that a low value on this parameter reduces the overshoot while a high value increase it.

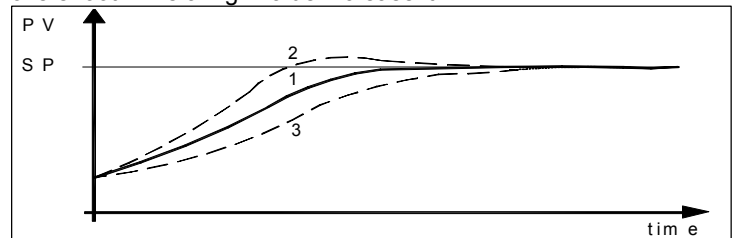

1: Value "FuOC" OK

2: Value "FuOC" too high

3: Value "FuOC" too low

4.5 - AUTOTUNING FUNCTION

The AUTOTUNING function foresees the calculation of the PID parameters through an OSCILLATING tuning cycle, which, when it ends, the parameters are memorized by the instrument and remain regular during regulation.

The function calculate the following parameters automatically:

"Pb" - Proportional ban

"tcr1" - output cycle time

"Int" - integral time

"dEr" - derivative time

"FuOC" - Fuzzy Overshoot Control

To activate the AUTOTUNING function, proceed as follows:

1) Set the Set point "SP1" desired.

2) Set the parameter "Cont" =Pid.

3) Set the parameter "Fun1" depending on the process to be controlled by the output OUT1.

4) Set the parameter "Auto" as:

= 1 - if the autotuning is to be started automatically each time the instrument is turned on.

= 2 - if the autotuning is to be started automatically when the instrument is turned on the next time and, once tuning has been completed, the parameter "Auto"=OFF is set automatically.

= 3 - if autotuning is started up manually, by the key U

= 4 - if autotuning is to be started automatically each time the regulation set is changed.

5) Exit the parameter programming mode.

6) Connect the instrument to the controlled system.

17	toF1	Deactivation time output OUT1 for probe broken	OFF ÷ 99.59 min.sec	OFF	
18	ton2	Activation time output OUT2 for probe broken	OFF ÷ 99.59 min.sec	OFF	
19	toF2	Deactivation time output OUT2 for probe broken	OFF ÷ 99.59 min.sec	OFF	
20	Cont	Control type: On.FA= ON/OFF nr= Neutral Zone ON/OFF Pid= PID (OUT1)	On.FA / nr / Pid	On.FA	
21	Fun1	Functioning mode OUT1: HEAt= Heating (reverse) Cool= Cooling (direct)	HEAt / Cool	HEAt	
22	Fun2	Functioning mode OUT2: see "Fun1"	HEAt / Cool	HEAt	
23	HSE1	Hysteresis OUT1	OFF ÷ 9999	1	
24	HSE2	Hysteresis OUT2	OFF ÷ 9999	1	
25	Ptd1	OUT1 delay	OFF ÷ 99.59 min.sec	OFF	
26	Ptd2	OUT2 delay	OFF ÷ 99.59 min.sec	OFF	
27	PtS1	OUT1 delay after switch off	OFF ÷ 99.59 min.sec	OFF	
28	PtS2	OUT2 delay after switch off	OFF ÷ 99.59 min.sec	OFF	
29	od	Outputs Delay at power on	OFF ÷ 99.59 min.sec	OFF	
30	Auto	Autotuning Fast enable OFF = Not active 1 = Start each power on 2= Start at first power on 3= Start manually 4= Start after change Set Point	OFF / 1 / 2 / 3 / 4	OFF	
31	Pb	Proportional band	0 ÷ 9999	40	
32	Int	Integral time	OFF ÷ 9999 sec.	300	
33	dEr	Derivative time	OFF ÷ 9999 sec.	30	
34	FuOc	Fuzzy overshoot control	0.00 ÷ 2.00	0.50	
35	tcr1	Cycle time	0.1 ÷ 130.0 sec.	20.0	
36	rS	Manual reset	-100.0 ÷ 100.0 %	0.0	
37	SLor	Gradient of SP1 ramp: InF= Ramp not active	0.00 ÷ 99.99 / InF unit/min.	InF	
38	AdE	Shift value for the shift index functioning	OFF...9999	5	
39	PASS	Access Password to parameter functions	OFF ÷ 9999	OFF	
40	r.PAS	Access Password Request	-1999 ÷ 9999		

6 - PROBLEMS, MAINTENANCE AND GUARANTEE

6.1 - ERROR SIGNALLING

Error	Reason	Action
----	Probe interrupted	Verify the correct connection between probe and instrument and then verify the correct functioning of the probe
uuuu	The measured variable is under the probe's limits (under-range)	
oooo	The measured variable is over the probe's limits (over-range)	

noAt	Auto-tuning not finished within 12 hours	Check the functioning of probe and actuator and try to repeat the auto-tuning.
ErEP	Possible anomaly of the EEPROM memory	Push key "P"

6.2 - CLEANING

We recommend cleaning of the instrument with a slightly wet cloth using water and not abrasive cleaners or solvents which may damage the instrument.

6.3 - GUARANTEE AND REPAIRS

The instrument is under warranty against manufacturing flaws or faulty material, that are found within 12 months from delivery date. The guarantee is limited to repairs or to the replacement of the instrument. The eventual opening of the housing, the violation of the instrument or the improper use and installation of the product will bring about the immediate withdrawal of the warranty's effects. In the event of a faulty instrument, either within the period of warranty, or further to its expiry, please contact our sales department to obtain authorisation for sending the instrument to our company. The faulty product must be shipped to TECNOLOGIC with a detailed description of the faults found, without any fees or charge for Tecnologic, except in the event of alternative agreements.

7 - TECHNICAL DATA

7.1 - ELECTRICAL DATA

Power supply: 24 VAC/VDC, 100.. 240 VAC +/- 10%

Frequency AC: 50/60 Hz

Power consumption: 5 VA approx.

Input/s: 1 input for temperature probes: tc J,K,S ; infrared sensors TECNOLOGIC IRS J e K; RTD Pt 100 IEC; PTC KTY 81-121 (990 Ω @ 25 °C); NTC 103AT-2 (10KΩ @ 25 °C) or mV signals 0...50 mV, 0...60 mV, 12 ...60 mV or normalized signals 0/4...20 mA, 0..1 V, 0/1...5 V , 0/2...10 V.

Normalized signals input impedance: 0/4...20 mA: 51 Ω; mV and V: 1 MΩ

Output/s: Up to 2 outputs. Relay SPDT (8 A-AC1, 3 A-AC3 / 250 VAC) ; or in tension to drive SSR (8mA/ 8VDC).

Auxiliary supply output: 12 VDC / 20 mA Max.

Electrical life for relay outputs: 100000 operat.

Installation category: II

Measurement category: I

Protection class against electric shock: Class II for Front panel

Insulation:

Reinforced insulation between the low voltage part (Supply and relay outputs) and front panel; Reinforced insulation between the low voltage section (Supply and relay outputs) and the extra low voltage section (input, SSR outputs); Reinforced between power supply and relays; No insulation between input and SSR outputs.

7.2 - MECHANICAL DATA

Housing: Self-extinguishing plastic, UL 94 V0

Dimensions: DIN 96 x 96 mm, depth 73 mm

Weight: 250 g approx.

Mounting: Flush in panel in 90 x 90 mm hole

Connections: 2,5 mm² screw terminals block

Degree of front panel protection : IP 54 mounted in panel with gasket

Pollution situation: 2

Operating temperature: 0 ... 50 °C

Operating humidity: 30 ... 95 RH% without condensation

Storage temperature: -10 ... +60 °C

7.3 - MECHANICAL DIMENSIONS, PANEL CUT-OUT AND MOUNTING [mm]

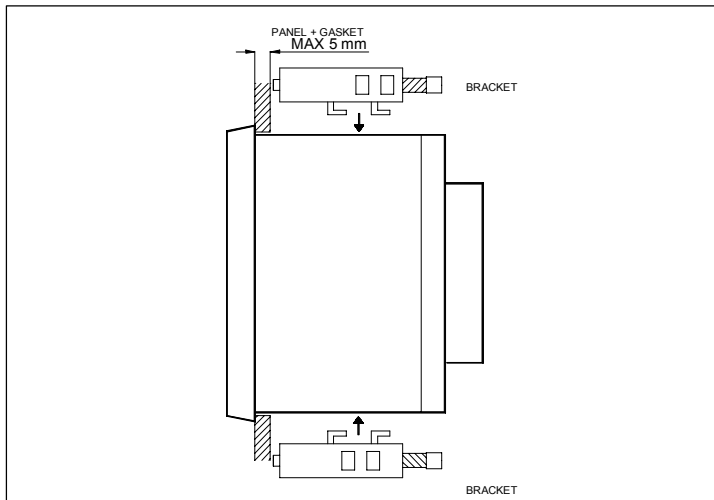
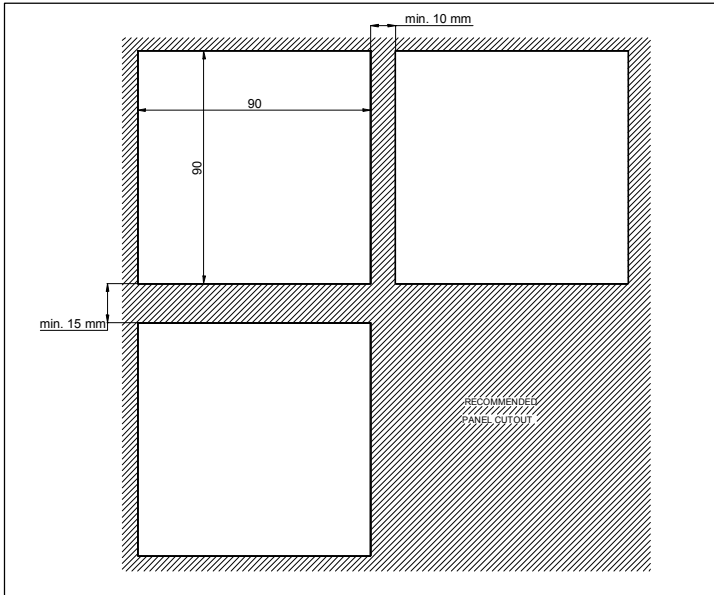
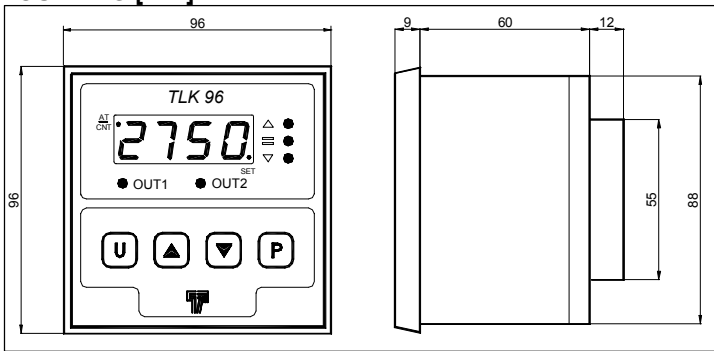

7.4 - FUNCTIONAL FEATURES

Control: ON/OFF, ON/OFF Neutral Zone, PID.

Measurement range: according to the used probe (see range table)

Display resolution: according to the probe used 1/0,1/0,01/0,001

Overall accuracy: +/- (0,5 % fs + 1 digit) ; tc S: +/- (1 % fs + 1 digit)

Max cold junction compensation drift (in tc) : 0,1 °C/°C with operating temperature 0 ... 50 °C after warm-up of 20 min.

Sampling rate: 130 ms.

Sampling rate: 130 ms.

Display: 4 Digit Red h 14 mm

Compliance: ECC directive EMC 89/336 (EN 61326), ECC directive LV 73/23 and 93/68 (EN 61010-1)

7.5 - MEASURING RANGE TABLE

INPUT	"dP" = 0	"dP" = 1, 2, 3
tc J "SEnS" = J	0 ... 1000 °C 32 ... 1832 °F	----
tc K "SEnS" = CrAl	0 ... 1370 °C 32 ... 2498 °F	----
tc S "SEnS" = S	0 ... 1760 °C 32 ... 3200 °F	----
Pt100 (IEC) "SEnS" = Pt1	-200 ... 850 °C -328 ... 1562 °F	-199.9 ... 850.0 °C -199.9 ... 999.9 °F
PTC (KTY81-121) "SEnS" = Ptc	-55 ... 150 °C -67 ... 302 °F	-55.0 ... 150.0 °C -67.0 ... 302.0 °F
NTC (103-AT2) "SEnS" = ntc	-50 ... 110 °C -58 ... 230 °F	-50.0 ... 110.0 °C -58.0 ... 230.0 °F
0..20 mA "SEnS" = 0.20		
4..20 mA "SEnS" = 4.20		
0 ... 50 mV "SEnS" = 0.50		
0 ... 60 mV "SEnS" = 0.60		
12 ... 60 mV "SEnS" = 12.60	-1999 ... 9999	-199.9 ... 999.9 -19.99 ... 99.99 -1.999 ... 9.999
0 ... 1 V "SEnS" = 0.1		
0 ... 5 V "SEnS" = 0.5		
1 ... 5 V "SEnS" = 1.5		
0 ... 10 V "SEnS" = 0.10		
2 ... 10 V "SEnS" = 2.10		

7.6 - INSTRUMENT ORDERING CODE

TLK96 a b c d ee S

a : POWER SUPPLY

L = 24 VAC/VDC

H = 100... 240 VAC

b : INPUT

C = thermocouples (J, K, S, I.R.), mV, thermoresistances (Pt100)

E = thermocouples (J, K, S, I.R.), mV, thermistors (PTC, NTC)

I = normalized signals 0/4..20 mA

V = normalized signals 0..1 V, 0/1..5 V, 0/2..10 V.

c : OUTPUT OUT1

R = Relay

O = VDC for SSR

d : OUTPUT OUT2

R = Relay

O = VDC for SSR

- = None

ee : SPECIAL CODES