



Z31Y- Z31SY

DIGITAL ELECTRONIC FREEZER CONTROLLER



OPERATING INSTRUCTIONS

Vr. 01 (ENG) - 07/09 - cod.: ISTR-MZ31YENG1

TECNOLOGIC S.p.A.

VIA INDIPENDENZA 56
27029 VIGEVANO (PV) ITALY

TEL.: +39 0381 69871

FAX: +39 0381 698730

internet : <http://www.tecnologic.it>

e-mail: info@tecnologic.it

FOREWORD



This manual contains the information necessary for the product to be installed correctly and also instructions for its maintenance and use; we therefore recommend that the utmost attention is paid to the following instructions and to save it.

This document is the exclusive property of TECNOLOGIC S.p.A. which forbids any reproduction and divulgation, even in part, of the document, unless expressly authorized.

TECNOLOGIC S.p.A. reserves the right to make any formal or functional changes at any moment and without any notice.

Whenever a failure or a malfunction of the device may cause dangerous situations for persons, things or animals, please remember that the plant has to be equipped with additional devices which will guarantee safety.

Tecnologic S.p.A. and its legal representatives do not assume any responsibility for any damage to people, things or animals deriving from violation, wrong or improper use or in any case not in compliance with the instrument's features.

INDEX

- 1 **INSTRUMENT DESCRIPTION**
 - 1.1 GENERAL DESCRIPTION
 - 1.2 FRONT PANEL DESCRIPTION
- 2 **PROGRAMMING**
 - 2.1 FAST PROGRAMMING OF SET POINT
 - 2.2 STANDARD MODE PARAMETERS PROGRAMMING
 - 2.3 PARAMETER PROTECTION USING THE PASSWORD
 - 2.4 CUSTOMIZED MODE PARAMETER PROGRAMMING (PARAMETERS PROGRAMMING LEVEL)
 - 2.5 RESET PARAMETERS TO DEFAULT VALUE/LEVEL
 - 2.6 PARAMETERS CONFIGURATION BY "A01"
 - 2.7 KEYBOARD LOCK FUNCTION
- 3 **INFORMATION ON INSTALLATION AND USE**
 - 3.1 PERMITTED USE
 - 3.2 MECHANICAL MOUNTING
 - 3.3 ELECTRICAL CONNECTIONS
 - 3.4 ELECTRICAL WIRING DIAGRAM
- 4 **FUNCTIONS**
 - 4.1 ON / STAND-BY FUNCTION
 - 4.2 MEASURING AND VISUALIZATION
 - 4.3 DIGITAL INPUT
 - 4.4 OUTPUTS AND BUZZER CONFIGURATION
 - 4.5 ACTIVE SET POINT SELECTION
 - 4.6 TEMPERATURE CONTROL
 - 4.7 COMPRESSOR PROTECTION FUNCTION AND DELAY AT POWER-ON
 - 4.8 DEFROST CONTROL
 - 4.8.1 AUTOMATIC DEFROST STARTS
 - 4.8.2 MANUAL DEFROST
 - 4.8.3 END DEFROST
 - 4.8.4 DEFROST DISPLAY LOCK
 - 4.9 EVAPORATOR FANS CONTROL
 - 4.10 ALARM FUNCTIONS
 - 4.10.1 TEMPERATURE ALARMS
 - 4.10.2 EXTERNAL ALARM (DIGITAL INPUT)
 - 4.10.3 OPEN DOOR ALARM
 - 4.11 FUNCTION OF KEYS "U" AND "DOWN/AUX"
- 5 **PROGRAMMABLE PARAMETERS TABLE**
- 6 **PROBLEMS, MAINTENANCE AND GUARANTEE**
 - 6.1 SIGNALLING
 - 6.2 CLEANING
 - 6.3 GUARANTEE AND REPAIRS
- 7 **TECHNICAL DATA**
 - 7.1 ELECTRICAL DATA
 - 7.2 MECHANICAL DATA
 - 7.3 MECHANICAL DIMENSIONS, PANEL CUT-OUT AND MOUNTING
 - 7.4 FUNCTIONAL DATA
 - 7.5 INSTRUMENT ORDERING CODE

1 - INSTRUMENT DESCRIPTION

1.1 - GENERAL DESCRIPTION

The model Z31Y is a digital controller with microprocessor that is typically used in cooling applications that have temperature control with ON/OFF regulation and defrosting control at intervals time or at reaching temperature by stopping compressor or by means of electrical heating or hot gas/reverse cycle.

The instrument has up to 2 relay outputs, up to 2 inputs for PTC or NTC temperature probes and a digital input (alternative to an temperature input), in addition can be equipped with an internal buzzer that is the sound system for alarms.

The 2 outputs can be can all be configured for controlling the compressor or the temperature control device and the defrosting device or, alternatively any of the previous functions, the evaporation fan or using an auxiliary device or an alarm.

The 2 inputs for temperature probes can be used to measure the control temperature, the evaporator temperature, products or aux temperature, while the digital input alternative to evaporator or aux temperature input can be programmed to carry out various functions such as door opened signal, defrosting commands, selecting a different set of temperature regulations, external alarm

signals, activating a continuous cycle, and activating an auxiliary output etc.
The model Z31SY have the "S-touch" capacitive sensor keyboard system.

1.2 - FRONT PANEL DESCRIPTION

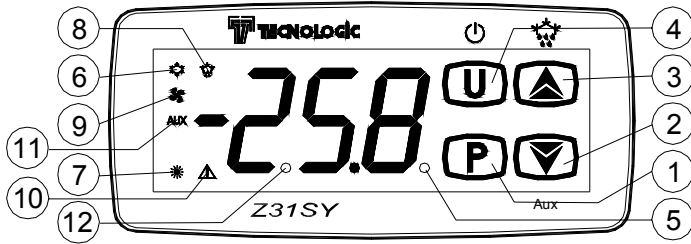

1 - Key P : Used for setting the Set point (press and release) and for programming the function parameters (hold pressed for 5 sec.) In programming mode is used to enter in parameters edit mode and confirm the values. In programming mode it can be used together with the UP key to change the programming level of the parameters.
When the keyboard is locked it can be used together with the UP (hold pressed for 5 sec.) key to unlock the keyboard.

2 - Key DOWN/Aux : In programming mode is used for decreasing the values to be set and for selecting the parameters. In normal mode it can also be programmed via the parameter "t.FB" to carry out other functions (hold pressed for 1 sec.) such as activating the Aux output, starting up the continuous cycle, etc. (see functions of keys U and Down).

3 - Key UP/DEFROST : In normal mode can be used to start/stop manual defrosting (hold pressed for 5 sec.). In programming mode is used for increasing the values to be set and for selecting the parameters. In programming mode can be used together with key P to change parameters level. Pressed together with the key P for 5 sec. allow the keyboard unlock

4 - Key U : Used (press and release) for visualising the instrument variables (measured temperatures etc.). In programming mode can be used to come back in normal mode (hold for 2 sec.). In normal mode it can also be programmed via the parameter "t.UF" to carry out other functions (hold pressed for 1 sec.) such as turning on and off (stand-by) the device, activating the Aux output, starting up the continuous cycle, etc. (see functions of keys U and Down).

5 - Led SET : In normal mode it serves to indicate when a key is pressed. In programming mode indicates the programming level of the parameters.

6 - Led OUT - COOL : Indicates the output status (compressor or temperature control device) when the instrument is programmed for cooling operation; on (on), off (off) or inhibited (flashing).

7 - Led OUT - HEAT : Indicates the output status (compressor or temperature control device) when the instrument is programmed for heating operation; on (on), off (off) or inhibited (flashing).

8 - Led DEFROST : Indicates defrosting in progress (on) or drainage time in progress (flashing)

9 - Led FAN : Indicates fan output status on (on), off (off) or delayed after defrosting (flashing)

10 - Led ALARM : Indicates the alarm status (on), off (off) and silenced or memorized (flashing)

11 - Led AUX : Indicates AUX output status on (on), off (off) or inhibited (flashing)

12 - Led Stand-By: Indicate the Stand-by status.

2 - PROGRAMMING

2.1 - FAST PROGRAMMING OF SET POINT

Press the key P then release it and the display will show "SP" (or "SP2" if the second set is active at that time) alternating with the set value.

To change it press the UP key to increase the value or DOWN to decrease it.

These keys increase or decrease the value one digit at a time, but if the button is pressed for more than one second the value

increase or decreases rapidly, and after two seconds pressed, the speed increases even more to all the desired value to be reached rapidly.

When the desired value is set press the key P to exit from Set Point programming mode.

Exiting the Set mode is achieved by pressing the P key or automatically if no key is pressed for 10 seconds. After that time the display returns to the normal function mode.

2.2 - STANDARD MODE PARAMETERS PROGRAMMING

To access the instrument's function parameters when password protection is disable, press the key P and keep it pressed for about 5 seconds, after which the display will visualised the code that identifies the first parameter.

Using the UP and DOWN keys, the desired parameter can be selected and pressing the P key, the display will alternately show the parameter code and its setting that can be changed with the UP and DOWN keys.

Once the desired value has been set, press the key P again: the new value will be memorised and the display will show only the code of the selected parameter.

Pressing the UP and DOWN keys, it is possible to select another parameter and change it as described.

To exit the programming mode, do not press any key for about 30 seconds, or keep the U key pressed for 2 sec. until it exits the programming mode.

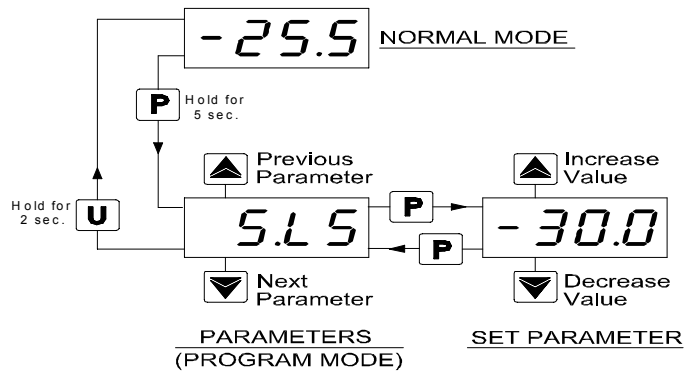

2.3 - PARAMETER PROTECTION USING THE PASSWORD

The instrument has a parameter protection function using a password that can be personalised, through the "t.PP" parameter. If one wishes to have this protection, set the password number desired in the parameter "t.PP".

When the protection is activate, press the P key to access the parameters and keep it press for about 5 seconds, after which the display will show "r.P".

At this point press P, the display show "0", using the UP and DOWN keys, set the password number programmed and press the key P.

If the password is correct, the display will visualise the code that identifies the first parameter and it will be possible to program the instrument in the same ways described in the previous section.

Protection using a password can be disabled by setting the parameter "t.PP" = oF.

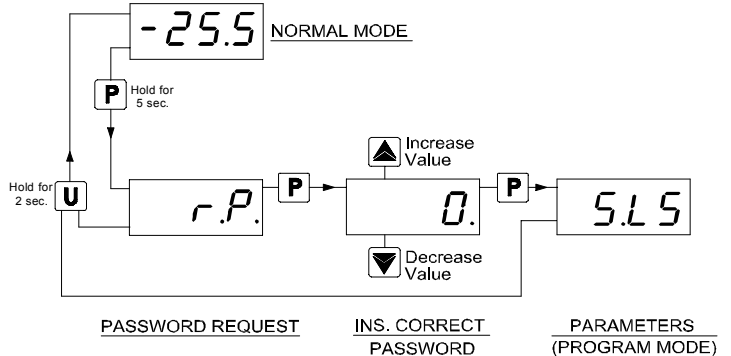

Note: If the Password gets lost, just swith off and on the instrument supply, push P key during the initial test and keeping the key pressed for 5 seconds.

In this way it's possible to have access to all the parameters, verify and modify the par. "t.PP".

2.4 - CUSTOMIZED MODE PARAMETER PROGRAMMING (PARAMETERS PROGRAMMING LEVEL)

The password protection hides all the configuration parameters behind a factory set password to avoid unwanted changes being made to the programming of the controller.

To make a parameter accessible without having to enter the password when "t.PP" password protection is activate follows this procedure.

Enter the programming using the Password "t.PP" and select the parameter which is desired to be accessible with no password protection.

Once the parameter has been selected, if the SET led is blinking, this means that the parameter is programmable by entering the password (it's then "protected") if it's instead on, this means the parameter is programmable without password (not protected).

If you want to change the accessibility of the parameter push P key, keep it pressed and press together also the key UP.

The led SET will change its state indicating the new access level of the parameter (on = not protected; blinking = protected by password).

In case some parameters are not protected, when one tries to have access at the programming, the display will show all the parameters not protected and the par. "r.P" (through which will be possible to have access to the "protected" parameters.)

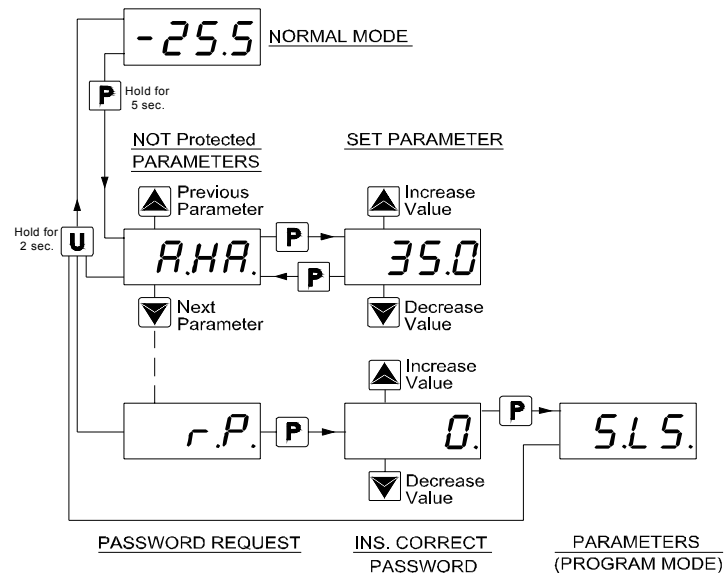

2.5 - RESET PARAMETERS TO DEFAULT VALUE/LEVEL

The instrument allows the reset of the parameters to values programmed in factory as default.

To restore to the values of default the parameters set the value **-48** to "r.P" password request.

Once confirmed the password with the key P the display it shows "---" for 2 sec. therefore the instrument effects the parameters reset

2.6 - PARAMETERS CONFIGURATION BY "A01"

The instrument is equipped with a connector that allows the transfer from and toward the instrument of the functioning parameters through the device **TECNOLOGIC A01** with 5 poles connector.

This device it's mainly useable for the serial programming of the instruments which need to have the same parameters configuration or to keep a copy of the programming of an instrument and allow its rapid retransmission.

The same device A01 allows the USB connection to a PC and through the "TECNOLOGIC UniversalConf" configuration software it is possible to program all the instrument parameters.

To use the device or A01 it's necessary that the device or instrument are being supplied.

For additional info, please have a look at the A01 instruction manual.

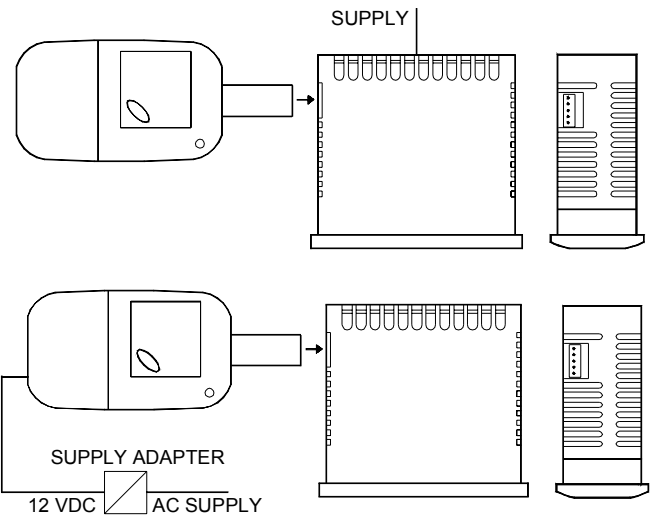

2.7 - KEYBOARD LOCK FUNCTION

On the instrument it's possible to lock completely the keyboard. This function is particularly useful when the regulator is reachable by the users and it's desired to avoid any modification.

To activate the keyboard lock it's enough program the par. "t.Lo" to a different value to 0F.

The value program to this parameter it is the time of inactivity of the keys afterwhich the keyboard will be locked.

Inssofar not pressing any key for the time "t.Lo" the instrument automatically disable the normal functions of the keys.

When the keyboard is lock, if any of the key is pushed, on the display will appear "Ln" to indicate the active lock.

To unlock the keyboard it's enough to contemporarily push key P and UP and keep them pushed for 5 sec., afterwhich the label "LF" will appear on the display and all the keys functions will be available again.

3 - INFORMATION ON INSTALLATION AND USE



3.1 - PERMITTED USE

The instrument has been projected and manufactured as a measuring and control device to be used according to EN60730-1 for the altitudes operation until 2000 ms. The use of the instrument for applications not expressly permitted by the above mentioned rule must adopt all the necessary protective measures. The instrument CANNOT be used in dangerous environments (flammable or explosive) without adequate protection. The installer must ensure that EMC rules are respected, also after the instrument installation, if necessary using proper filters. Whenever a failure or a malfunction of the device may cause dangerous situations for persons, thing or animals, please remember that the plant has to be equipped with additional devices which will guarantee safety.

3.2 - MECHANICAL MOUNTING

The instrument, in case 78 x 35 mm, is designed for flush-in panel mounting. Make a hole 71 x 29 mm and insert the instrument, fixing it with the provided special brackets. We recommend that the gasket is mounted in order to obtain the front protection degree as declared. Avoid placing the instrument in environments with very high humidity levels or dirt that may create condensation or introduction of conductive substances into the instrument. Ensure adequate ventilation to the instrument and avoid installation in containers that house devices which may overheat or which may cause the instrument to function at a higher temperature than the one permitted and declared. Connect the instrument as far away as possible from sources of electromagnetic disturbances such as motors, power relays, relays, solenoid valves, etc.

3.3 - ELECTRICAL CONNECTION

Carry out the electrical wiring by connecting only one wire to each terminal, according to the following diagram, checking that the power supply is the same as that indicated on the instrument and that the load current absorption is no higher than the maximum

electricity current permitted. As the instrument is built-in equipment with permanent connection inside housing, it is not equipped with either switches or internal devices to protect against overload of current: the installation will include an overload protection and a two-phase circuit-breaker, placed as near as possible to the instrument, and located in a position that can easily be reached by the user and marked as instrument disconnecting device which interrupts the power supply to the equipment. It is also recommended that the supply of all the electrical circuits connected to the instrument must be protected properly, using devices (ex. fuses) proportionate to the circulating currents. It is strongly recommended that cables with proper insulation, according to the working voltages and temperatures, be used. Furthermore, the input cable of the probe has to be kept separate from line voltage wiring. If the input cable of the probe is screened, it has to be connected to the ground with only one side. Whether the instrument is F o G (12 / 24 V) supply version it's recommended to use an external transformer TCTR, or with equivalent features (Class II insulation), and to use only one transformer for each instrument because there is no insulation between supply and input. We recommend that a check should be made that the parameters are those desired and that the application functions correctly before connecting the outputs to the actuators so as to avoid malfunctioning that may cause irregularities in the plant that could cause damage to people, things or animals.

3.4 - ELECTRICAL WIRING DIAGRAM

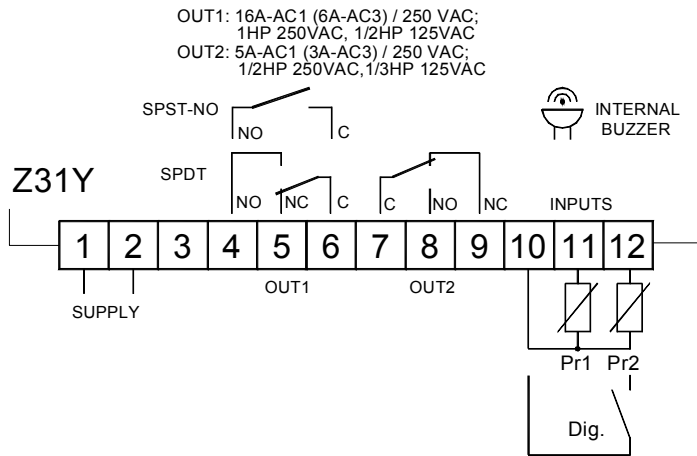

4 - FUNCTIONS

4.1 - ON / STAND-BY FUNCTION

The instrument, once powered up, can assume 2 different conditions:

- ON : means that the controller uses the control functions.
 - STAND-BY : means that the controller does not use any control function and the display is turned off except for the Stand-by led.
- If there is no power, and then power returns, the system always sets itself in the condition it was in before the black-out.

The ON/Stand-by function can be selected:

- Pressing the key U for at least 1 sec. if the parameter "**t.UF**" = 4.
- Pressing the key DOWN/AUX for at least 1 sec. if the parameter "**t.Fb**" = 4.
- using the digital input if the parameter "**i.Fi**" = 10

4.2 - MEASURING AND VISUALIZATION

Via the parameter "**i.SE**" it is possible to select the type of probes that one wishes to use and which can be: thermistores PTC KTY81-121 (**Pt**) or NTC 103AT-2 (**nt**).

Via the parameter "**i.uP**", it is possible to select the temperature unit of measurement the desired measurement resolution (**C0**=°C / 1°; **C1**=°C / 0.1°; **F0**= °F / 1°; **F1**= °F / 0.1°).

The instrument allows the measuring to be calibrated, that can be used for re-calibrating the instrument according to application needs, through the parameters "**i.C1**" (for the input Pr1) and "**i.C2**" (for the input Pr2).

The functions carried out by Pr2 probe is defined by the parameter "**i.P2**".

This parameter can be configured for the following functions:

= **EP** - Evaporator probe: used to managing the defrost and the evaporator fans (see relative functions)

= **Au** - Auxiliary probe

= **dG** - Digital input (see Digital input functions)

If probe Pr2 is not used, set the relative parameter "**i.P2**"= oF.

Using the parameter "**i.Ft**", it is possible to set the time constant for the software filter for measuring the input values to be able to reduce the sensitivity to measurement disturbances (increasing the time).

Through the paragraph "**i.dS**", it is possible to fix the normal visualisation on the display that can be the measurement of the probe Pr1 (P1), the measurement of the probe Pr2 (P2), the active set point value (SP), or it can have the numerical display switched off (oF).

Through the paragraph "**i.CU**", it is possible to program an measure offset that will be applied to the temperature show on the display (only if **i.dS**= P1, P2).

All the controls will always happen in operation of the measure corrected only by the calibration parameters ("**i.C1**", "**i.C2**").

The normal visualisation on the display is established by par. "**i.dS**", but it is possible to visualise all the variables and the highest and lowest Pr1 peak measurement values in rotation by quickly pressing and releasing key U.

The display will alternately show the code that identifies the variable and its value.

The variable are:

"**Pr1**" - Pr1 temperature

"**Pr2**" - Pr2 temperature (on/oF state if is progr. as digital input)

"**Lt**" and the lowest Pr1 peak temperature

"**Ht**" and the highest Pr1 peak temperature

When the instrument is switched off, peak values are always re-set. However, it is also possible to reset these values if the instrument is switched on by using the DOWN key hold for 3 sec. during peak visualization.

The display will show "---" and peaks memory will be reset.

The exit of this visualisation mode occurs automatically 15 seconds after the last pressing on the key U.

Please remember that visualisation of the Pr1 probe can be changed by the defrosting display lock function, by using the parameter "**d.dL**" (see defrost function).

4.3 - DIGITAL INPUT

The digital input present on the instrument, alternative to Pr2 probe, accepts free voltage contacts, the function carried out is defined by the parameter "**i.Fi**" and the action can be delayed for the time set in parameter "**i.ti**".

If digital input is used, set the input relative parameter "**i.P2**" = dG.

The parameter "**i.Fi**" can be configured for the following functions:

= **0** - No function

= **1** - Defrosting start command with contact normally open: on closing the digital input 1 (and after the "**i.ti**" time) a defrosting cycle is activated.

= **2** - Defrosting end command with contact normally open: on closing the digital input 1 (and after the "**i.ti**" time) a defrosting cycle is ended if in progress or defrosting is inhibited.

= **3** - continuous cycle activation command with contact normally open: on closing the digital input (and after the "**i.ti**" time) a continuous cycle is started up as described in the paragraph on the continuous cycle function.

= **4** - External alarm signal with contact normally open: on closing the digital input (and after the "**i.ti**" time) the alarm is activated and the instrument visualises **AL** and the variable set in parameter "**i.dS**" alternately on the display.

= **5** - Cell door opening with fan stop with contact normally open: on closing the digital input (and after the "**i.ti**" time) the fans are stopped and the instrument visualises **oP** and the variable set in parameter "**i.dS**" alternately on the display. With this function mode, the action of the digital input also activates the time that can be set in parameter "**A.oA**" after which the alarm is activated to signal that the door has been left open and the fan restart.

= **6** - Cell door opening with compressor and fan stop with contact normally open: similar to "**i.Fi**" = 5 but with fan and compressor

stop. At the intervention of the door open alarm compressor and fan restarts.

= **7** - Remote control of auxiliary output AUX with contact normally open: on closing the digital input (and after the "i.ti" time) the auxiliary output is activated as described in the "i.Fo" = 2 function mode of the auxiliary output.

= **8** - Selecting the active set point (SP/SP2) with contact normally open: on closing the digital input (and after the "i.ti" time) the temperature set point "SP2" is activated. When instead the input is open the set point "SP" is active.

= **9** - Signalling of external alarm with disablement of all the control outputs with contact normally open: on closing the digital input (and after the "i.ti" time) all the control outputs are disabled, the alarm is activated and the instrument visualises **AL** and the variable set in parameter "i.dS" alternately on the display.

= **10** - Switching on/switching off (Stand-by) of instrument with contact normally open: on closing the digital input (and after the "i.ti" time) the instrument is switched on while it is placed in Stand-by when opened.

= **11** - Selecting the active set point (SP/SP2) and heating/cooling control mode with contact normally open: on closing the digital input (and after the "i.ti" time) the temperature set point "SP2" with cooling action is activated. When instead the input is open the set point "SP" with heating action is active.

= **-1, -2, -3, -4, -5, -6, -7, -8, -9, -10** - Like "i.Fi" with positive values but with function logic reversed (contact normally closed)

4.4 - OUTPUTS AND BUZZER CONFIGURATION

The instrument outputs can be configured by the relative parameters "o.o1", "o.o2".

The outputs can be configured for the following functions:

= **ot** - to control the compressor or however, the temperature control device

= **dF** - to control the defrosting device

= **Fn** - to control the fans

= **Au** - to control the auxiliary device

= **At** - to control a silenceable alarm device through a contact that is normally open, and then closed when the alarm sounds

= **AL** - to control an alarm that cannot be silenced through a contact that is normally open and closed when the alarm sounds.

= **An** - to control an alarm with a memory function through a contact that is normally open and closed when the alarm sounds.

= **-At** - to control a silenceable alarm device through a contact that is normally closed, and then open when the alarm sounds.

= **-AL** - control an alarm that cannot be silenced through a contact that is normally closed and open when the alarm sounds.

= **-An** - to control an alarm with a memory function through a contact that is normally closed and open when the alarm sounds (see alarm memory).

= **on** - Output on when the instrument is in on state. This mode can be used to control lights, non-misting resistance on room door or other utilities

= **oF** - Disabled output

The function carried out for auxiliary output (par. desired output = Au) is defined by the parameter "o.Fo" and the function is conditioned by the time set in parameter "o.tu".

The parameter "o.Fo" can be configured for the following functions:

= **oF** - Auxiliary output not active

= **1** - Temperature control output delayed with contact normally open: the auxiliary output is activated with delay that can be set on the parameter "o.tu" compared to the output configured as ot. The output is then turned off at the same time as the ot output is disabled. This function mode can be used as a command for a second compressor or for all other working utilities according to the same ot output conditions, but which must be delayed after the start up of the compressor to avoid excess electricity absorption.

= **2** - Activation by front key (U or DOWN/AUX) or by digital input with contact normally open: the output is activated by pressing the keys U or DOWN/AUX suitably configured ("t.UF" or "t.Fb" = 1) or via activation of the digital input if suitably configured ("i.Fi"=7). These commands have a bi-stable function, which means that when first pressed, the output key is activated while the second is disabled. In this mode, the AUX output can be turned off

automatically after a certain time that can be set on the parameter "o.tu". With "o.tu" = oF the output is activated and deactivated only manually, using the key (U or DOWN/AUX) or via the digital input. Differently, the output, once activated, is turned off automatically after the set time. This function can be used, for example, as a cell light command, for non-misting resistance or other utilities.

= **3** - Light output managed by Active set point ("economy" function).

This output will be on in "normal" mode (Set Point "SP" active) and off in economy mode operation (Set Point "SP2" active).

= **4** - Internal Light output managed by digital input. This output will be on when door is opened ("i.Fi"= 5, 6).

The internal buzzer (if present) can be configured by par. "o.bu" for the following functions:

oF = Buzzer always disable

1 = Buzzer signal active alarms only

2 = Buzzer signal key pressed only (no alarm)

3 = Buzzer signal active alarms and key pressed

4.5 - ACTIVE SET POINT SELECTION

The instrument allows up to 2 different Set points to be pre-set ("SP" and "SP2") and then to choose which one to make active.

This function can be used if it is necessary to switch two different function temperatures (e.g. day and night or positive and negative etc).

The active set point can be selected:

- Using the parameter "S.SA"

- using the key U if the parameter "t.UF" = 3.

- Using the key DOWN/AUX if the parameter "t.Fb" = 3.

- Using the digital input if the parameter. "i.Fi" = 8 or 11

The selection of the Set point active can be also combined to the function of switch off Auxiliary output if used as light ("o.Fo" = 3) and to Heating/Cooling change action by digital input ("i.Fi"=11).

The Set points "SP" and "SP2" can be set with a value between the programmed value in parameter. "S.LS" and the programmed value in parameter "S.HS".

Note: in the examples that follow, the Set point is generally indicated as "SP", how when operating the instrument will work according to the Set point selected as active.

4.6 - TEMPERATURE CONTROL

The regulation of the instrument is ON/OFF and acts on the output configured as "ot" depending on the measuring of probe Pr1, of the active Set Point "SP" (or "SP2"), the intervention differential "r.d" and the function mode "r.HC".

Depending on the function mode programmed on the parameter "r.HC" the differential is automatically considered by the regulator with positive values for a Refrigeration control ("r.HC"=C) or with negative values for a heating control ("r.HC"=H).

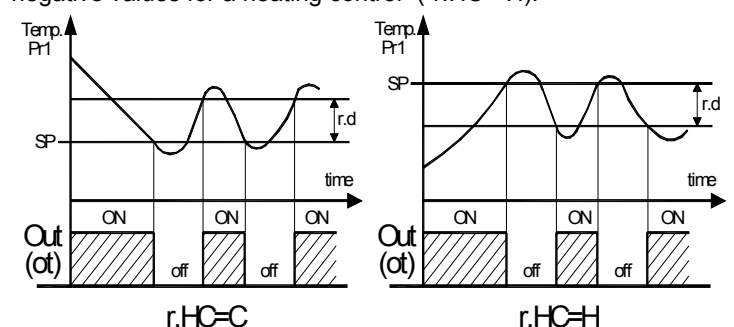

In the event of probe error, it is possible to set the instrument so that the output continues to work in cycles according to the times programmed in the parameter "r.t1" (activation time) and "r.t2" (deactivation time).

If an error occurs on the probe the instrument activates the output for the time "r.t1", then deactivates it for the time "r.t2" and so on whilst the error remains.

Programming "r.t1" = oF the output in probe error condition will remain switched off.

Programming instead "r.t1" to any value and "r.t2" = oF the output in probe error condition will remain switched on.

Remember that the temperature regulation function can be conditioned by the "Continuous Cycle", "Compressor Protection and output delay at power-on", "Defrost", "Door open" and "external alarm with outputs disable" functions.

4.7 - COMPRESSOR PROTECTION FUNCTION AND DELAY AT POWER-ON

The function "Compressor Protection" aims to avoid close start ups of the compressor controlled by the instrument in cooling applications.

This function foresees 3 time controls on the switching on of the output configured as "ot" associated with the temperature regulation request.

The protection consists of preventing the output being switched on during the times set in the parameters "P.P1", "P.P2" and "P.P3" and therefore that any activation occurs only after all the times has finished.

First control (par. "P.P1") foresees a delay to the output activation (switching-on delay).

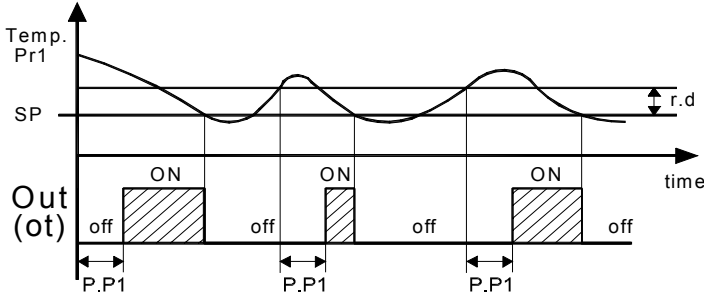

Second control (par. "P.P2") foresees an inhibition to the activation of the output by a time delay that starts when the output is turning off (delay after switching-off).

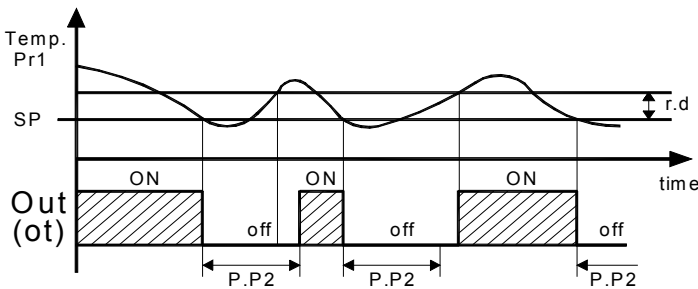

Third control (par. "P.P3") foresees an inhibition to the activation of the output "Out" by a time delay that starts when the output was turning on last time (delay between switching-on).

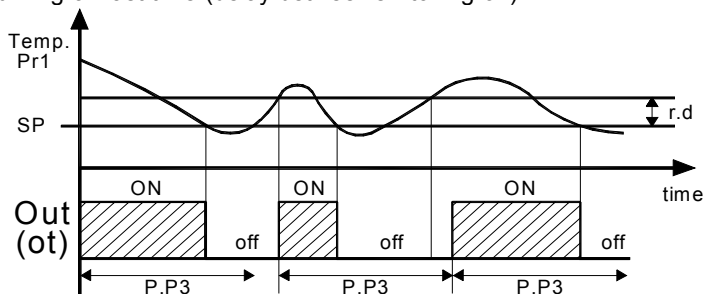

During the output inhibition the led OUT (Cool o Heat) blinking. It is also possible to prevent activation of the output after the instrument is turned on, for the time set in the parameter "P.od". During the power on delay phase, the display shows the indication od, alternating with the normal visualisation. All the functions are disabled by relative parameters = oF.

4.8 - DEFROST CONTROL

The defrosting control acts on the outputs configured as "ot" and "dF".

The type of defrosting that the instrument must carry out is set by the parameter "d.dt" that can be programmed:

= **EL** - WITH ELECTRICAL HEATING (or BY STOPPING COMPRESSOR): during defrosting, the output "ot" is deactivated while the output "dF" is enabled.

The defrost will be by Stopping compressor if not using the "dF" output

= **in** - WITH HOT GAS or INVERSION OF CYCLE:

during defrosting the outputs "ot" and "dF" are enabled

= **no** - WITHOUT COMPRESSOR OUTPUT CONDITIONING:

during defrosting, the output "ot" continuous to operate in order to temperature controller while the output "dF" is enabled.

= **Et** - WITH ELECTRICAL HEATING AND DEFROSTING TEMPERATURE CONTROL: during defrosting, the output "ot" is deactivated while the output "dF" operate as evaporator temperature control. In this mode the defrost lenght is by time-out (time "d.dE"). During the defrost "dF" output it behaves as an heating mode temperature control with Set = "d.tE" and fixed differential at 1°C and operate in order to evaporator probe (EP).

4.8.1 - AUTOMATIC DEFROST STARTS

The automatic control of defrost occurs by interval times.

The automatic defrost function is activate when at the parameter "d.di" is set the defrost interval time.

The first defrost after switching on can be set by par. "d.Sd"

This allows to perform the first defrost to a different interval from "d.di." time.

If it is desired that to every instrument power on a defrost cycle is realized (as long as the conditions set in the parameters "tS" and "tE" apply) program the par. "d.Sd" = oF.

This allows the evaporator to be permanently defrosted, even when frequent interruptions to power supply occur that may cause the cancellation of the various defrosting cycles.

Instead if is desired all defrost to the same interval program "d.Sd" = "d.di."

Automatic defrost function is disable when "d.di" = oF.

Counting mode interval and automatic defrost starts is set through the parameter "d.dC" that can be programmed:

= **rt** - intervals with counts the total function time (instrument on)

This mode results that currently used in the refrigerators systems.

= **ct** - intervals with counts only the compressor function time (output "ot" switched on)

Mode typically used in the positive temperature refrigerators system with defrost by stopping compressor.

= **cS** - the instrument carries out a defrosting cycle at each compressor stop (i.e. at each deactivation of the output "ot") or however at defrost interval end with counts the total function time (instrument on).

If "d.di" = oF the defrost happens only to the compressor stop.

This mode is used only on particular refrigerator system in which is desired to always have the evaporator to the maximum efficiency conditions every compressor cycle.

= **St** - Defrost for temperature evaporator. The instrument starts a defrost cycle when the temperature evaporator ("EP" probe) goes below the "d.tS" programmed temperature or however at defrost interval end with counts the total function time (instrument on).

If "d.di" = oF the defrost happens only when the evaporator temperature goes below "d.tS" temperature.

This system can be used in heat pump defrost system (in this case the defrosting intervals are usually disabled) or to guarantee a defrost if the evaporator reaches very low temperatures that normally result symptomatic of a bad thermal exchange in comparison to the normal working conditions.

= **dd** - "DYNAMIC DEFROST INTERVALS SYSTEM". This mode allows to dynamically reduce in progress the defrost interval counting ("d.di" or "d.Sd" if is the first defrost), anticipating so the execution of a defrost when it was necessary, in order to an algorithm that allows to notice a decrease performances of refrigerator thermal exchange.

Besides it maintains activates the mode "St" that it allows a further possibility of control of the defrost in order to notice a decrease performances of refrigerator thermal exchange.

The algorithm allows to esteem a reduction of thermal exchange in base to the increase of the difference of temperature between Pr1 (controlled temperature) and evaporator ("EP" probe) that is memorized by the instrument in proximity of the Set Point.

The advantage of the "Dynamic Defrost Interval" is the possibility to program a defrost interval time more longer than normal.

The instrument will have the possibility to anticipate the defrost if necessary or to start the cycle after the programmed time. If the system results set correctly is possible to avoid many non necessary defrosting cycles (and therefore to obtain an energy saving) that could instead happens in the normal operation when, to guarantee with greater certainty the system efficiency, the defrost interval is programmed at a too low time.

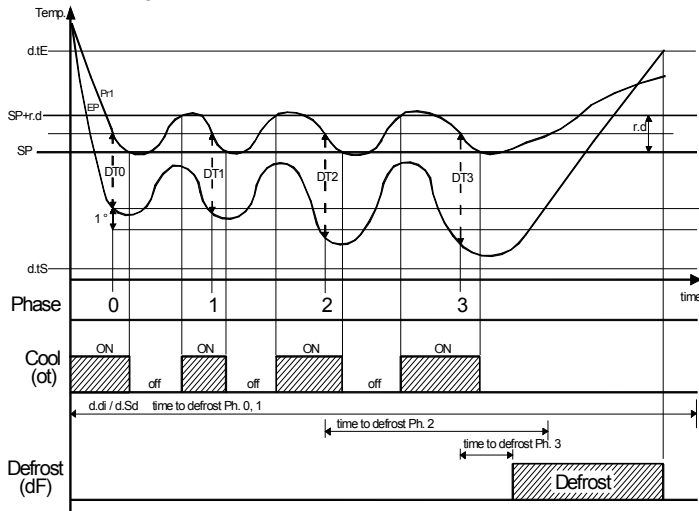

Example "dynamic defrost intervals system" with a reduction "d.dd" = 40 % and end defrost by temperature.

In addition to normal defrost parameters the "Dynamic Defrost Intervals System", it foresees the parameter:

"d.dd" - DEFROST INTERVAL PERCENTAGE REDUCTION. It allows to establish the percentage of reduction of the remaining time to start defrost when the conditions for the reduction happen. If par. "d.dd" = 100% at the first increase of the memorized difference of temperature between cell (Pr1) and evaporator ($> 1^\circ$) a defrost start immediately

For correct functioning the instrument needs a first reference value of the temperature difference between cell and evaporator.

Every variation of the value of the Active Set Point, of the differential "r.d", the start of a continuous cycle or the a defrost execution delete this reference value and any reduction will be performed until the acquisition of a new reference value.

4.8.2- MANUAL DEFROST

To start up a manual defrosting cycle, press the key UP/DEFROST when it is not in programming mode and keep it pressed for about 5 seconds after which, if the conditions are correct, the led Defrost will light up and the instrument will carry out a defrosting cycle.

To stop a defrosting cycle, press the key UP/DEFROST during a defrost cycle and keep it pressed for about 5

The start up or switch off commands of a defrosting cycle can also be given by the digital input that are correctly programmed (see Digital input).

4.8.3 - DEFROST ENDS

The automatic defrosting cycle can be ended by time or, if an evaporator probe is used ("EV" probe), when a temperature on the evaporator is reached.

If the evaporator probe is not used or it is program the defrost temperature control (par. "d.dy" = Et) the duration cycle is set by the parameter "d.dE".

If instead the evaporator probe is used it is not program the defrost temperature control (par. "d.dy" = EL, in, no) the defrost cycle end when the temperature measured by the evaporator probe exceeds the temperature set in the parameter "d.tE".

If this temperature is not reached in the time set in the parameter "d.dE", defrosting is interrupted.

In order to avoid pointless defrosting the parameter "d.tS" in "d.dC" = rt, ct, cS mode is foreseen that sets the enablement temperature for defrosting

If the temperature measured by the probe is higher than the one set in the parameter "d.tS" and in the parameter "d.tE" the defrosting is inhibited.

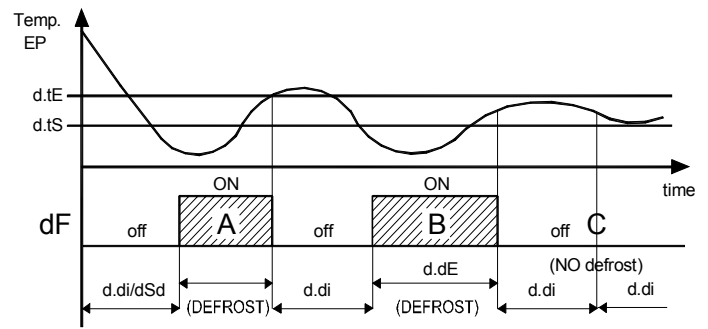

Examples: defrosting A ends due to reaching of temperature "d.tE", defrosting B ends at the end of the "d.dE" time as the temperature "d.tE" is not reached, defrosting C does not take place as the temperature is higher than "d.tS".

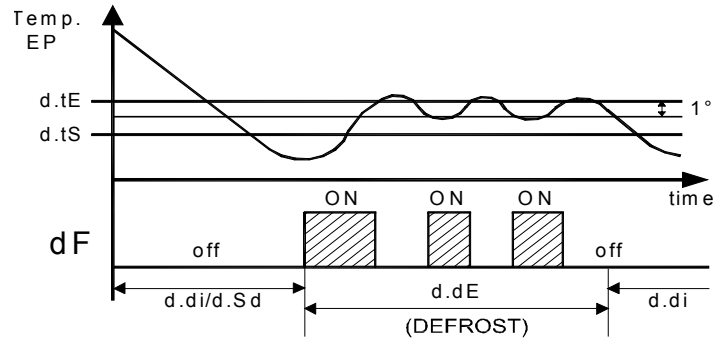

Example of electric defrost with evaporator temperature control: The defrost end after "d.dE" programmed time. During defrost the "dF" output switch on/off to control evaporator temperature in heating mode with set point "d.tE" and 1° differential (Hysteresis).

The active defrost is shown on the instrument display with the lighting up of the DEFROST led

At the end of defrosting, it is possible to delay the new start up of the compressor (output "ot") at the time set in parameter "d.td" to allow the evaporator to drain.

During this delay, the led Defrost flashes to indicate the draining state.

4.8.4 - DEFROST DISPLAY LOCK

Through par. "d.dL" and "A.dA" it's possible to define the display behaviour during defrost.

The "d.dL" parameter permits the display visualization lock on the last Pr1 emperature reading ("d.dL" = on) during all the defrost cycle until, at the end of defrost, the temperature has not reached the lock value or the value ["SP" + "r.d"] or is elapsed the time setted on par. "A.dA".

Or it permits only the visualization of label "dEF" ("d.dL" = Lb) during the defrost cycle and, after the defrost, of label "PdF" until, at the end of defrost, the Pr1 temperature has not reached the lock value or the value ["SP" + "r.d"] or is elapsed the time setted on par. "A.dA".

The display will otherwise ("d.dL" = oF) continue to visualize the Pr1 temperature measured by the probe during the defrost cycle.

4.9 - EVAPORATOR FANS CONTROL

The control of the fans on the output configured as "Fn" depending on determined control statuses of the instrument and the temperature measured by the evaporator probe (EV).

In the case that the evaporator probe is not used or in error, the output Fn is activated only depending on the parameters "F.tn", "F.tF" and "F.FE".

The parameters "F.tn" e "F.tF" decides the funs functioning when the output configured as "ot" (compressor) is off.

When output "ot" is off, it is possible to set the instrument so that that the output "Fn" continues to work in cycles according to the times programmed in the parameter "F.tn" (fan activation time) and "F.tF" (fan deactivation time).

When output "ot" is switched off the instrument activates the output "Fn" for the time "F.tn", then deactivates it for the time "F.tF" and so on whilst the output "ot" remains off.

Programming "F.tn" = oF the output "Fn" in "ot" off condition will remain switched off.

Programming instead "F.tn" to any value and "F.tF" = oF the output "Fn" in "ot" off condition will remain switched on.

The parameter "F.FE" instead decides whether the fans must always be switched on independently of the defrosting status ("F.FE"=on) or switched off during defrosting ("F.FE"=oF).

In this latter case, it is possible to delay the start up of the fans even after the end of the defrosting of the time set in the parameter "F.Fd".

When this delay is active the led FAN flashing to signal the delay in progress.

When the evaporator probe is used the fans, as well as being conditioned by the parameters "F.tn", "F.tF" and "F.FE", are also conditioned by a temperature control.

It is possible to set the disablement of the fans when the temperature measured by the evaporator probe is higher than the one set in the parameter "F.FL" (temperature too hot) or when it is lower than the one set in the parameter "F.LF" (temperature too cold).

The relative differential that can be set in parameter "F.dF" is also associated with these parameters.

Notes: It is necessary to pay attention to the correct use of this fans temperature control functions because in the typical application of refrigeration the stop of the fans evaporator stops thermal exchange.

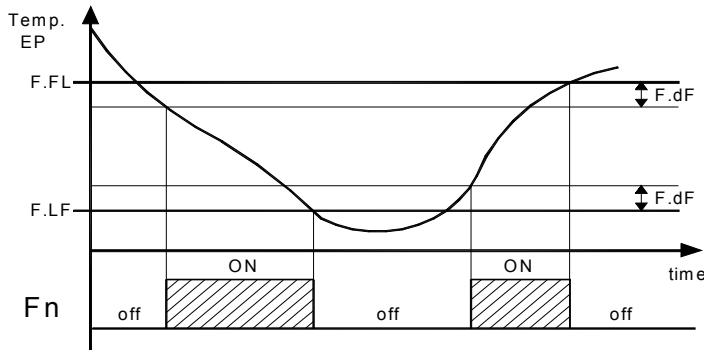

Remember that the fans functioning can be conditioned by the "Door open" function by the digital input.

4.10 - ALARM FUNCTIONS

The alarm conditions of the instrument are:

- Probe errors: "E1", "E1", "E2", "E2"
- temperature alarms: "Hi" and "Lo"
- External alarm: "AL"
- Open door alarm: "oP"

The alarm functions of the instrument work on the ALARM led, on internal buzzer (if present and programmed by par. "o.bu") and on output desired, if configured by the parameters "o1", "o2", depending on what is set on the said parameters.

Any active alarm is shown on the instrument display with the lighting up of the ALARM led, the silenced or memorized alarm status is shown by the ALARM led flashing.

The buzzer (if "o.bu" = 1 or 3) is activated in alarm and can be disabled (alarm silencing) manually by pressing any key of the instrument.

The possible selections of output parameters for the alarm signalling function are:

= **At** - when one wants the output to be activated in alarm and can be disabled (alarm silencing) manually by pressing any key of the instrument (typical application for sound signal).

= **AL** - when one wants the output to be activated in alarm status but cannot be disabled manually and are therefore only disabled when the alarm status ceases (typical application for a light signal).

= **An** - when one wants the output to be activated in alarm status and that they remain activated even when the alarm has ceased (see par.4.10.4) Disablement (recognition of memorised alarm) can

only be carried out manually by pressing any key when the alarm has ended (typical application for light signal).

= **-At** - when one wants the function described as At but with an inverse function (output activated in normal condition and disabled in alarm status).

= **-AL** - when one wants the function described as AL but with inverse logic (output activated in normal conditions and disabled in alarm status).

= **-An** - when one wants the function described as An but with inverse working logic (output activated in normal conditions and disabled in alarm status).

The instrument offers the possibility of arranging the alarm memory function via the parameter "A.tA".

If "A.tA" = oF, the instrument cancels the alarm signal when the alarm status ends, if instead it is programmed as "on", the instrument maintains the alarm signal when the alarm status ends.

To cancel the alarm memory signal, press any key.

It must be remembered that if an output function is desired with an alarm memory (=An or =-An) it is necessary to set the parameter "A.tA" = on.

4.10.1 - TEMPERATURE ALARMS

The temperature alarms work according to the programmed probe measurement, the type of alarm set in the parameter "A.Ay" the alarm thresholds set in parameters "A.HA" (maximum alarm) and "A.LA" (minimum alarm) and the relative differential "A.Ad".

Through the parameter "A.Ay" it is possible to set if the alarm thresholds "A.HA" and "A.LA" must be considered as absolute or relative to the Set Point, if the reference temperature must be Pr1 or "Au" probe measurement and if the display must show the messages Hi (maximum alarm)/ Lo (minimum alarm) to the intervention of the alarms or no.

The possible selections of the parameter "A.Ay" are:

- = 1 : Pr1 Absolute Alarms with labels (Hi - Lo)
- = 2 : Pr1 Relative Alarms with labels (Hi - Lo)
- = 3 : "Au" probe Absolute Alarms with labels (Hi - Lo)
- = 4 : "Au" probe Relative Alarms with labels (Hi - Lo)
- = 5 : Pr1 Absolute Alarms without labels
- = 6 : Pr1 Relative Alarms without labels
- = 7 : "Au" probe Absolute Alarms without labels
- = 8 : "Au" probe Relative Alarms without labels

Using some parameters it is also possible to delay the enablement and the intervention of these alarms.

These parameters are:

"**A.PA**" - is the temperature alarm exclusion time on switching on the instrument if the instrument is in alarm status when it is switched on.

If the instrument at power on is not in temperature alarm conditions the time "A.PA" is not considered.

"**A.dA**" - is the temperature alarm exclusion time at the end of defrosting (and, if programmed, at the end of draining) and at the end of a continuous cycle.

"**A.At**" - is the temperature alarm delay activation time

The temperature alarm is enabled at the end of exclusion time and is enabled after the "A.At" time when the temperature measured by the probe exceeds or goes below the respective maximum and minimum alarm thresholds.

The alarm thresholds will be the same as those set on the parameters "A.HA" and "A.LA" if the alarms are absolute ("A.Ay"=1, 3, 5, 7).

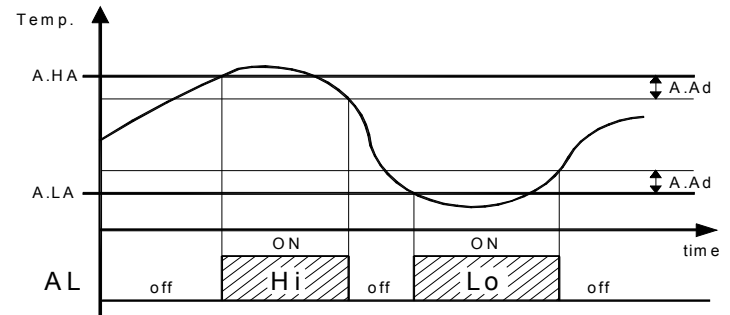

or will be the values ["SP"+"A.HA"] and ["SP"+"A.LA"] if the alarms are relative ("A.Ay"=2, 4, 6, 8).

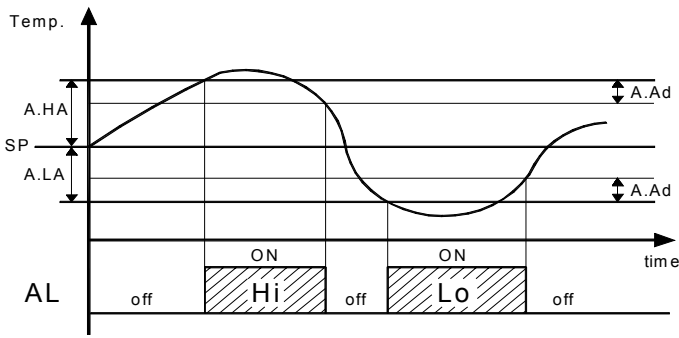

The maximum and minimum temperature alarms can be disabled by setting the relative parameters "A.HA" and "A.LA" = oF.

4.10.2 - EXTERNAL ALARM

The instrument can signal an external alarm by activating the digital input with the function programmed as "i.Fi" = 4 or 9.

At the same time as the signalling of the configured alarm output, the instrument visualising **AL** and the variable set in parameter "i.dS" alternately on the display.

In alarm conditions with "i.Fi" = 9 all the control outputs will be off.

4.10.3 - OPEN DOOR ALARM

The instrument can signal an open door alarm by activating the digital input with the function programmed as "Fi" = 5 or 6.

When the digital input is activated the instrument show **oP** and after the delay programmed in parameter "A.oA", the instrument signals the alarm via the activation of the configured alarm output (buzzer/output).

At the intervention of the open door alarm the inhibited output will be reactivated (fans or fans + compressor).

4.11 - FUNCTIONING OF KEYS "U" AND "DOWN/AUX"

Two of the instrument keys, in addition to their normal functions, can be configured to operate other commands.

The U key function can be defined by the parameter "t.UF" while the DOWN/AUX key function can be defined by the parameter "t.Fb"

Both the parameters have the same possibilities and can be configured for the following functions:

=oF - The key carries out no function.

= 1 - Pressing the key for at least 1 second, it is possible to enable/disable the auxiliary output if configured ("o.Fo"=2).

= 2 - Pressing the key for at least 1 second, it is possible to enable/disable a continuous cycle.

= 3 - Pressing the key for at least 1 second, it is possible to select one of the 2 memorised set point in rotation. Once selection has been made, the display will flash the active set point code for about 1 sec. (SP, SP2).

= 4 - Pressing the key for at least 1 second, it is possible to switch the instrument from the ON status to Stand-by status and vice versa.

5 - PROGRAMMABLE PARAMETERS TABLE

Here below is a description of all the parameters available on the instrument. Some of them may not be present because depend on the model/type of instrument.

Par.	Description	Range	Def.	Note
S. - parameters relative to Set Point				
1	S.LS Minimum Set Point	-99.9 ÷ HS	-50.0	
2	S.HS Maximum Set Point	LS ÷ 999	99.9	
3	S.SA Active Set Point	1 ÷ 2	1	
4	SP Set Point (1)	S.LS ÷ S.HS	0.0	
5	SP2 Set Point 2	S.LS ÷ S.HS	0.0	
i. -parameters relative to inputs				
6	i.SE Probes Type	Pt / nt	nt	
7	i.uP Unit of measurement and resolution (decimal point) C0 = °C with 1° res.	C0 / F0 / C1 / F1	C1	

		F0 = °F with 1° res. C1 = °C with 0,1° res. F1 = °F with 0,1° res.		
8	i.Ft	Measurement filter	oF ÷ 20.0 sec	2.0
9	i.C1	Pr1 Probe Calibration	-30.0 ÷ 30.0 °C/°F	0.0
10	i.C2	Pr2 Probe Calibration	-30.0 ÷ 30.0 °C/°F	0.0
11	i.CU	Measure offset on the display	-30.0 ÷ 30.0 °C/°F	0.0
12	i.P2	Pr2 input function	oF / EP / Au / dG	EP
13	i.Fi	Function and function logic of digital input: 0 = No function 1 = Start defrost 2 = End defrost 3 = Continuous cycle 4 = External alarm 5 = Door open with fan stop 6 = Door open with fan and compressor stop 7 = Auxiliary output command 8 = Selection of active Set Point 9 = External alarm with deactivation of control outputs 10 = Switch on/Switch off (Stand-by) 11 = Selection of active Set Point and control action (SP-H, SP2-C)	-11 / -10 / -9 / -8 / -7 / -6 / -5 / -4 / -3 / -2 / -1 / 0 / 1 / 2 / 3 / 4 / 5 / 6 / 7 / 8 / 9 / 10 / 11	0
14	i.ti	Delay in acquiring digital input	oF / 0.01 ÷ 9.59 (min.sec.) ÷ 99.5 (min.sec.x10)	oF
15	i.dS	Variable visualized normally on display: oF=Display off P1= measurement probe Pr1 P2= measurement probe Pr2 P3 = measurement probe Pr3 SP= Active Set Point	P1 / P2 / P3 / SP / oF	P1
r. - parameters relative to temperature control				
16	r.d	Differential (Hysteresis)	0.0 ÷ 30.0 °C/°F	2.0
17	r.t1	Output activation time for probe error	oF / 0.01 ÷ 9.59 (min.sec.) ÷ 99.5 (min.sec.x10)	oF
18	r.t2	Output deactivation time for probe error	oF / 0.01 ÷ 9.59 (min.sec.) ÷ 99.5 (min.sec.x10)	oF
19	r.HC	Output operating mode H= Heating C= Cooling	H - C	C
20	r.tC	Continuous cycle Time	oF / 0.01 ÷ 9.59 (hrs.min.) ÷ 99.5 (hrs.min.x10)	oF
d. - parameters relative to defrosting control				
21	d.dt	Defrosting Type:	EL / in / no / Et	EL

		EL= Electrical heating/stop. compr. in= hot gas/reverse cycle no= without compr. output conditioning Et= Electrical heating with evaporator temperature control		
22	d.di	Defrosting interval	oF/ 0.01 ÷ 9.59 (hrs.min.) ÷ 99.5 (hrs.min.x10)	6.00
23	d.Sd	Delay first defrost after power-on (oF = Defrost at power-on)	oF/ 0.01 ÷ 9.59 (hrs.min.) ÷ 99.5 (hrs.min.x10)	6.00
24	d.dE	Lenght (max.) of defrost cycle	oF/ 0.01 ÷ 9.59 (min.sec) ÷ 99.5 (min.sec.x10)	20.0
25	d.tE	Defrost stop temperature	- 99.9 ÷ 999 °C/°F	8.0
26	d.tS	Defrost enable temperature (d.dC = rt or ct) or start (d.dC=St)	- 99.9 ÷ 999 °C/°F	2.0
27	d.dC	Defrosting starting mode: rt = real time intervals ct = "ot" output on time intervals cS = defrost every "ot" switching off (+ rt intervals) St = defrost for Pr2<"d.tS" (+ rt intervals dd = "dynamic defrost intervals" (+ Pr2<"d.tS")	rt / ct / cS / St / dd	rt
28	d.dd	Dynamic Defrost Percentage reduction	0 ÷ 100 %	50
29	d.td	Compressor delay after defrost (drainage time)	oF/ 0.01 ÷ 9.59 (min.sec) ÷ 99.5 (min.sec.x10)	oF
30	d.dL	Defrost display Lock oF= display free on= Lock on temperature Pr1 before defrost Lb= Lock on label "dEF" (during defrosting) and "PdF" (during post-defrosting)	oF / on / Lb	oF
F. - parameters relative to evaporator fans control				
31	F.tn	Fan time activation with ot output (compressor) off	oF/ 0.01 ÷ 9.59 (min.sec) ÷ 99.5 (min.sec.x10)	5.00
32	F.tF	Fan time deactivation with ot output (compressor) off	oF/ 0.01 ÷ 9.59 (min.sec) ÷ 99.5 (min.sec.x10)	oF
33	F.FL	High temperature fan deactivation	- 99.9 ÷ 999 °C/°F	10.0
34	F.LF	Low temperature fan deactivation	- 99.9 ÷ 999 °C/°F	-99.9
35	F.dF	Differential fan control	0.0 ÷ 30.0 °C/°F	1.0

36	F.FE	Fan status during defrost	oF - on	oF
37	F.Fd	Fan delay after defrost	oF/ 0.01 ÷ 9.59 (min.sec) ÷ 99.5 (min.sec.x10)	oF
P. parameters relative to compressor protection and power on delay				
38	P.P1	Output "ot" delay at switch on	oF/ 0.01 ÷ 9.59 (min.sec) ÷ 99.5 (min.sec.x10)	oF
39	P.P2	Output "ot" delay after switch off	oF/ 0.01 ÷ 9.59 (min.sec) ÷ 99.5 (min.sec.x10)	oF
40	P.P3	Output "ot" delay between switching-on	oF/ 0.01 ÷ 9.59 (min.sec) ÷ 99.5 (min.sec.x10)	oF
41	P.od	Delay outputs at power on	oF/ 0.01 ÷ 9.59 (min.sec) ÷ 99.5 (min.sec.x10)	oF
A. - parameters relative to alarms				
42	A.Ay	Temperature alarms Type: 1 = Pr1 absolute with label (Hi - Lo) 2 = Pr1 Relative with label (Hi - Lo) 3 = "Au" absolute with label (Hi - Lo) 4 = "Au" Relative with label (Hi - Lo) 5 = Pr1 absolute without label 6 = Pr1 relative without label 7 = "Au" absolute without label 8 = "Au" relative without label	1 / 2 / 3 / 4 / 5 / 6 / 7 / 8	1
43	A.HA	High temperature Alarm threshold	oF / -99.9 ÷ 999 °C/°F	oF
44	A.LA	Low temperature Alarm threshold	oF / -99.9 ÷ 999 °C/°F	oF
45	A.Ad	Temperature Alarms Differential	0.0 ÷ 30.0 °C/°F	1.0
46	A.At	Temperature Alarms delay	oF/ 0.01 ÷ 9.59 (min.sec) ÷ 99.5 (min.sec.x10)	oF
47	A.tA	Alarm memory	oF - on	oF
48	A.PA	Temperature Alarms delay at power on	oF/ 0.01 ÷ 9.59 (hrs.min.) ÷ 99.5 (hrs.min.x10)	2.00
49	A.dA	Temperature Alarms delay after defrost and continuous cycle, and unlock display delay after defrost	oF/ 0.01 ÷ 9.59 (hrs.min.) ÷ 99.5 (hrs.min.x10)	1.00
50	A.oA	Alarm delay with door open	oF/ 0.01 ÷ 9.59 (min.sec) ÷ 99.5 (min.sec.x10)	3.00
o. - parameters relative to configuration of outputs and buzzer				
51	o.o1	OUT1 function: oF= No function	oF/ot/dF/ Fn/Au/At/	ot

		ot= Temperature control (compressor) dF= Defrosting Fn= fan Au= Auxiliary At= Silenceable alarm AL= Not silenceable Alarm An= Memorised alarm on= on when instrument switch on	AL/An/ -At/ -AL/ -An / on		
52	o.o2	OUT2 function: see "o.o1"	oF/ot/dF/ Fn/Au/At/ AL/An/ -At/ -AL/ -An / on	dF	
53	o.bu	Buzzer function mode oF = disable 1 = active alarms only 2 = key pressed only 3 = active alarms and key pressed	oF / 1 / 2 / 3	3	
54	o.Fo	Function mode auxiliary output: oF= No Function 1= control output "ot" delayed 2= manual activation by key or digital input. 3 = light with economy mode (on with "SP" and off with "SP2") 4 = internal light (off with door closed and on with door opened)	oF / 1 / 2 / 3 / 4	oF	
55	o.tu	Time relative to auxiliary output	oF/ 0.01 ÷ 9.59 (min.sec) ÷ 99.5 (min.sec.x10)	oF	
t. - parameters relative to configuration of the keyboard					
56	t.UF	Function mode key DOWN/AUX: oF= No function 1= Auxiliary output command 2= Continuous cycle command 3= Selection of active Set Point (+ light off-economy mode) 4= Switch on/off (Stand-by)	oF / 1 / 2 / 3 / 4	oF	
57	t.Fb	Function mode key Down/Aux: see "t.UF"	oF / 1 / 2 / 3 / 4	oF	
58	t.Lo	Keyboard lock function delay	oF/ 0.01 ÷ 9.59 (min.sec) ÷ 30.0 (min.sec.x10)	oF	
59	t.PP	Access Password to parameter functions	oF ÷ 999	oF	

6 - PROBLEMS, MAINTENANCE AND GUARANTEE

6.1 - SIGNALLING

Error	Reason	Action
E1 -E1 E2 -E2	The probe may be interrupted (E) or in short circuit (-E), or may measure a value outside the range allowed	Check the correct connection of the probe with the instrument and check the probe works correctly
EPr	Internal EEPROM memory error	Press key P

Other Signalling:

Message	Reason
od	Delay at power-on in progress
Ln	Keyboard lock
Hi	Maximum temperature alarm in progress
Lo	Minimum temperature alarm in progress
oP	Door opened
dEF	Defrosting in progress with "d.dL"=Lb
PdF	Post-defrosting in progress with "d.dL"=Lb

6.2 - CLEANING

We recommend cleaning of the instrument only with a slightly wet cloth using water and not abrasive cleaners or solvents.

6.3 - GUARANTEE AND REPAIRS

The instrument is under warranty against manufacturing flaws or faulty material, that are found within 12 months from delivery date.

The guarantee is limited to repairs or to the replacement of the instrument.

The eventual opening of the housing, the violation of the instrument or the improper use and installation of the product will bring about the immediate withdrawal of the warranty's effects.

In the event of a faulty instrument, either within the period of warranty, or further to its expiry, please contact our sales department to obtain authorisation for sending the instrument to our company.

The faulty product must be shipped to TECNOLOGIC with a detailed description of the faults found, without any fees or charge for Tecnologic, except in the event of alternative agreements.

7 - TECHNICAL DATA

7.1 - ELECTRICAL DATA

Power supply: 12 VAC/VDC, 12...24 VAC/VDC, 100...240 VAC +/- 10%

Frequency AC: 50/60 Hz

Power consumption: 4 VA approx.

Input/s: 2 inputs for temperature probes: PTC (KTY 81-121, 990 Ω @ 25 °C) or NTC (103AT-2, 10KΩ @ 25 °C); 1 digital input for free voltage contacts (alternative to Pr2 input)

Output/s: up to 2 relay outputs. OUT1 SPDT o SPST-NO (16A-AC1, 6A-AC3 250 VAC, 1 HP 250 VAC, 1/2HP 125 VAC); OUT2 SPDT (5A-AC1, 3A-AC3 250 VAC, 1/2 HP 250 VAC, 1/3 HP 125 VAC); 12 A Max. for extractable terminal block model

Electrical life for relay outputs: SPST-NO: 100000 op. ; SPDT: 50000 op. (om. VDE)

Action type: type 1.B (EN 60730-1)

Overvoltage category: II

Protection class : Class II

Insulation: Reinforced insulation between the low voltage part (supply H type and relay outputs) and front panel; Reinforced insulation between the low voltage section (supply H type and relay outputs) and the extra low voltage section (inputs); Reinforced between supply and relay outputs; No insulation between supply F or G type and inputs.

7.2 - MECHANICAL DATA

Housing: Self-extinguishing plastic, UL 94 V0

Heat and fire resistance category: D

Dimensions: 78 x 35 mm, depth 64 mm

Weight: 125 g approx.

Mounting: Flush in panel (thickness max. 12 mm) in 71 x 29 mm hole

Connections: 2,5 mm² screw terminals block or 2,5 mm² extractable screw terminals block

Degree of front panel protection : IP 65 mounted in panel with gasket

Pollution situation: 2

Operating temperature: 0 T 50 °C

Operating humidity: < 95 RH% without condensation

Storage temperature: -25 T 60 °C

7.3 - MECHANICAL DIMENSIONS, PANEL CUT-OUT AND MOUNTING [mm]

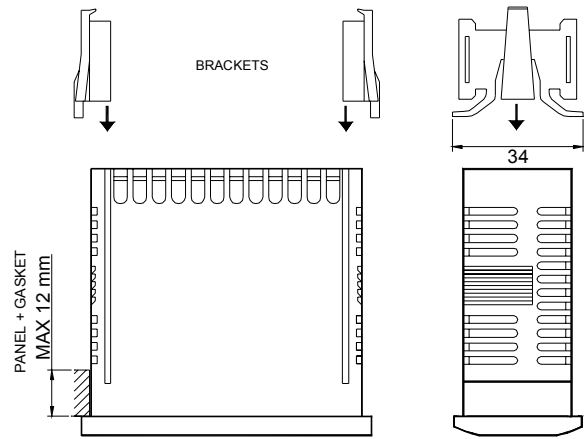
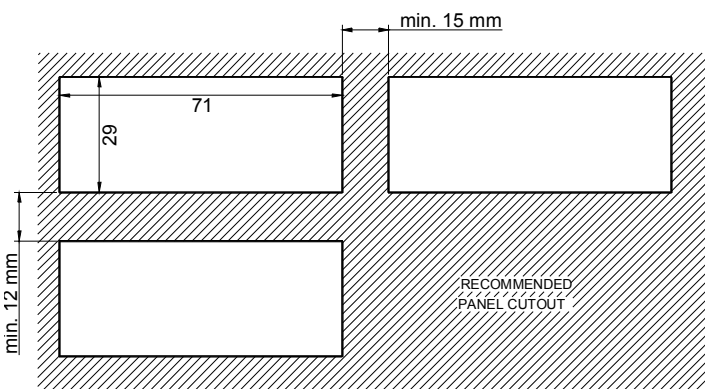
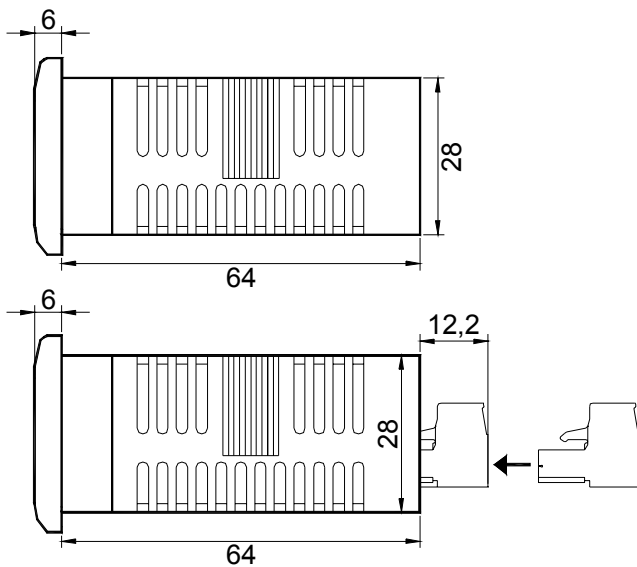
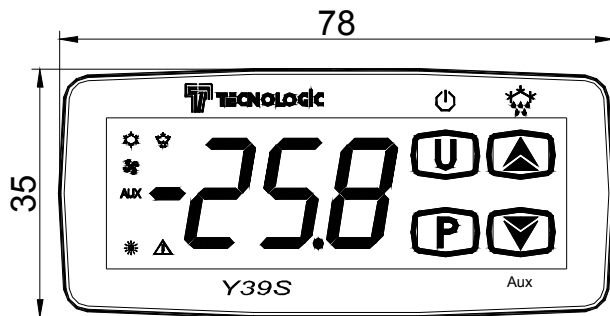
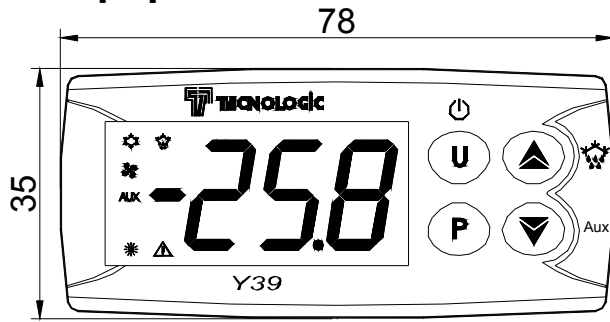

7.4 - FUNCTIONAL FEATURES

Temperature Control: ON/OFF mode

Defrost control: interval cycles or evaporator temperature by

Electric Heating /stopping compressor or hot-gas / reverse cycle

Measurement range: NTC: -50...109 °C / -58...228 °F; PTC: -50...150 °C / -58 ... 302 °F

Display resolution: 1 ° or 0,1°

Overall accuracy: +/- (0,5 % fs + 1 digit)

Sampling rate: 130 ms.

Display: 3 Digit Red (Blue optional) h 15,5 mm

Software class and structure : Class A

Compliance: ECC directive EMC 2004/108/CE (EN55022: class B; EN61000-4-2: 8KV air, 4KV cont.; EN61000-4-3: 10V/m; EN61000-4-4: 2KV supply, inputs, outputs; EN61000-4-5: supply 2KV com. mode, 1 KV diff. mode; EN61000-4-6: 3V), LV 2006/95/CE (EN 60730-1, EN 60730-2-7, EN 60730-2-9)

7.5 - INSTRUMENT ORDERING CODE

Z31Y (instrument with mechanical keyboard)

Z31SY (instrument with Sensitive Touch keyboard)

a b c d e f g h i j j k k

a : POWER SUPPLY

H = Supply 100..240 VAC

G = Supply 12..24 VAC/VDC

F = Supply 12 VAC/VDC

b : OUT1

R = Out1 Relay SPST-NO 16A-AC1

S = Out1 Relay SPDT 16A-AC1

c : OUT2

R = Out2 Relay SPDT 5A-AC1

- = (No)

d: BUZZER

B = Buzzer

- = (No)

e : TERMINAL BLOCK

- = (Standard)

E = Extractable

f : DISPLAY

- = Red

B = Blue

g, h, i : INTERNAL CODES

jj, kk : SPECIAL CODES